

UPS5000-H-(1200 kVA-1600 kVA)

Product Description (100 kVA Power Modules)

Issue 06
Date 2022-02-11



Copyright © Huawei Technologies Co., Ltd. 2022. All rights reserved.

No part of this document may be reproduced or transmitted in any form or by any means without prior written consent of Huawei Technologies Co., Ltd.

Trademarks and Permissions



HUAWEI and other Huawei trademarks are trademarks of Huawei Technologies Co., Ltd.

All other trademarks and trade names mentioned in this document are the property of their respective holders.

Notice

The purchased products, services and features are stipulated by the contract made between Huawei and the customer. All or part of the products, services and features described in this document may not be within the purchase scope or the usage scope. Unless otherwise specified in the contract, all statements, information, and recommendations in this document are provided "AS IS" without warranties, guarantees or representations of any kind, either express or implied.

The information in this document is subject to change without notice. Every effort has been made in the preparation of this document to ensure accuracy of the contents, but all statements, information, and recommendations in this document do not constitute a warranty of any kind, express or implied.

Huawei Technologies Co., Ltd.

Address: Huawei Industrial Base
Bantian, Longgang
Shenzhen 518129
People's Republic of China

Website: <https://www.huawei.com>

Email: support@huawei.com

About This Document

Purpose

This document describes the UPS5000-H-(1200 kVA–1600 kVA) in terms of model description, positioning, features, application scenarios, configurations, architecture, technical specifications, and acronyms and abbreviations.



Intended Audience



This document is intended for:

- Sales engineers
- System engineers
- Technical support engineers

Symbol Conventions

The symbols that may be found in this document are defined as follows.

Symbol	Description
 DANGER	Indicates a hazard with a high level of risk which, if not avoided, will result in death or serious injury.
 WARNING	Indicates a hazard with a medium level of risk which, if not avoided, could result in death or serious injury.
 CAUTION	Indicates a hazard with a low level of risk which, if not avoided, could result in minor or moderate injury.

Symbol	Description
 NOTICE	Indicates a potentially hazardous situation which, if not avoided, could result in equipment damage, data loss, performance deterioration, or unanticipated results. NOTICE is used to address practices not related to personal injury.
 NOTE	Supplements the important information in the main text. NOTE is used to address information not related to personal injury, equipment damage, and environment deterioration.

Change History

Changes between document issues are cumulative. The latest document issue contains all updates made in previous issues.

Issue 06 (2022-02-11)

Updated the appearance of the 1200 kVA standard configuration.

Issue 05 (2021-10-13)

Added the three-phase three-wire model in the 380 V AC/400 V AC/415 V AC voltage system.

Issue 04 (2021-08-03)

- Added the top air exhaust feature of the 1600 kVA model.
- Added the S-ECO mode.

Issue 03 (2021-03-25)

Added the 1600 kVA model.

Issue 02 (2020-10-15)

Updated certain technical specifications.

Issue 01 (2020-07-15)

This issue is the first release.

Contents

About This Document	iii
1 Product Overview	1
1.1 Positioning	1
1.2 Features	1
1.3 Application Scenarios.....	2
1.4 Working Principle.....	5
1.5 Working Modes.....	6
1.5.1 Normal Mode.....	6
1.5.2 Bypass Mode.....	7
1.5.3 Battery Mode.....	7
1.5.4 S-ECO Mode.....	8
1.5.5 ECO Mode (The System Can Work in ECO Mode If the Model or Hardware Does Not Support S-ECO)	9
1.5.6 Source-Share Mode.....	9
2 Product Description	11
2.1 Model Description (Three-Phase Four-Wire).....	11
2.2 Model Description (Three-Phase Three-Wire).....	12
2.3 Cabinet Description (1200 kVA, Three-Phase Four-Wire).....	13
2.3.1 Standard Configuration	13
2.3.2 Top Cabling Configuration	15
2.3.3 Bottom Cabling Configuration.....	16
2.3.4 Top Air-Flow Configuration	17
2.3.5 Top Air-Flow + Top Cabling Configuration	18
2.4 Cabinet Description (1200 kVA, Three-Phase Three-Wire)	19
2.4.1 Standard Configuration	19
2.4.2 Top Cabling Configuration	21
2.4.3 Bottom Cabling Configuration.....	22
2.4.4 Top Air-Flow Configuration	23
2.4.5 Top Air-Flow + Top Cabling Configuration	24
2.5 Cabinet Description (1600 kVA, Three-Phase Four-Wire).....	25

UPS5000-H-(1200 kVA-1600 kVA) Product Description (100 kVA Power Modules)	Contents
<hr/>	
2.5.1 Standard Configuration	25
2.5.2 Top Cabling Configuration	27
2.5.3 Bottom Cabling Configuration.....	28
2.5.4 Top Air-Flow Configuration	29
2.5.5 Top Air-Flow + Top Cabling Configuration	30
2.6 Cabinet Description (1600 kVA, Three-Phase Three-Wire)	31
2.6.1 Standard Configuration	31
2.6.2 Top Cabling Configuration	33
2.6.3 Bottom Cabling Configuration.....	34
2.6.4 Top Air-Flow Configuration	35
2.6.5 Top Air-Flow + Top Cabling Configuration	36
3 Component Description	37
3.1 Power Module	37
3.2 Bypass Module	38
3.3 Control Module.....	40
3.3.1 Overview	40
3.3.2 ECM.....	41
3.3.3 Dry Contact Card.....	43
3.3.4 Monitoring Interface Card.....	46
3.4 Intelligent Detection Card.....	51
3.5 Surge Protection Box.....	54
3.6 MDU.....	55
4 Optional Components	58
4.1 List of Optional Components.....	58
4.2 Dry Contact Extended Card	59
4.3 Backfeed Protection Card.....	61
4.4 BCB Box.....	62
4.5 Ambient T/H Sensor	63
4.6 Top Air-Flow Cabinet.....	65
4.7 Bottom Cabling Cabinet.....	66
4.8 Rear Copper Bar Protection Component	66
4.9 Top Cabling Component.....	67
4.10 Inductor Cabinet.....	68
4.10.1 Rectifier	69
5 Technical Specifications.....	72
5.1 Physical Specifications	72
5.2 Environmental Specifications.....	74
5.3 Safety Compliance and ECM Specifications	75

UPS5000-H-(1200 kVA-1600 kVA) Product Description (100 kVA Power Modules)	Contents
5.4 Mains Input Electrical Specifications.....	76
5.5 Bypass Input Electrical Specifications	77
5.6 Battery Electrical Specifications	77
5.7 Output Electrical Specifications	79
5.8 System Electrical Specifications	81
A Lifting Trolley	83
B Acronyms and Abbreviations.....	85

1 Product Overview

1.1 Positioning

The UPS5000-H is a high-end modular UPS launched by the Company. It adopts online double conversion and modular redundancy design for components. Thanks to digital control, the UPS provides high efficiency and power density.

The UPS5000-H provides reliable, efficient, and simple solutions. It supplies reliable and high-quality power to:

- Large-sized data centers
- ISP data centers
- Internet data centers
- DR data centers
- Cloud data centers
- Infrastructures, large-sized control equipment rooms, and railways

1.2 Features

Simple

- Power, bypass, and control modules are hot swappable. A common engineer can finish maintenance within 5 minutes.
- Smooth capacity expansion is supported. The initial investment on the UPS is reduced and the UPS operating efficiency is improved.
- The UPS is configured with an SNMP card, which reduces the management cost and features simple and flexible configurations. The NetEco easily implements remote centralized management.
- The power supply and distribution status is monitored in real time. Core parameters of the UPS power supply and distribution system are automatically inspected, so manual inspection is not required.

Green

- Space is efficiently used. The UPS saves space for placing more IT equipment and reduces the footprint by 50% compared with traditional solutions of combining cabinets.
- The power density of power modules is the highest in the industry.
- High efficiency is ensured even with a low load rate. If the load rate is extremely low, the intelligent rotation hibernation technology ensures redundancy and improves the UPS efficiency.

Intelligent

The iPower fault warning function is supported. If a battery, capacitor, fan, or any other key component fails, a warning is generated to prevent the fault from escalating.

Safe

- UPS power and control modules use redundant design. No single-point fault occurs.
- The product supports a wide input voltage range to adapt to poor power grids.
- The UPS has an output power factor (PF) of 1.0, which is suitable for linear and non-linear loads with a PF greater than 0.5. This allows the UPS to connect to more loads and reduces customer investments.
- The UPS passes reliability tests which focus on high temperature, high humidity, and dust adaptation. The impact of environment on the UPS reliability is reduced.

1.3 Application Scenarios

The UPS5000-H is suitable for power systems in various indoor scenarios, including large-sized data centers or communications centers, equipment rooms of large-sized enterprises, equipment rooms of financial systems, industrial automated equipment, and scheduling centers.

Table 1-1 Typical UPS configurations

Configuration	Application Scenario	Description
Single UPS	Supplies power to common loads.	-

Configuration	Application Scenario	Description
Parallel system	Supplies power to large-sized data centers or important loads. It features high reliability and strong transient overload resistance capability.	1200 kVA: A maximum of four UPSs can be connected in parallel. (For details about a parallel system where three-phase three-wire input and output cables are connected using a busway, contact marketing engineers.) 1600 kVA: A maximum of two UPSs can be connected in parallel. (For details about a parallel system where three-phase three-wire input and output cables are connected using a busway, contact marketing engineers.)
Dual-bus system	Supplies power to important loads in large- and medium-sized equipment rooms, data centers, and other places that require high reliability. In addition to advantages of common parallel systems, the dual-bus system is free from bottleneck failures, but its configuration is complex.	Supports dual-bus synchronization.

 **NOTE**

For the three-phase four-wire model, if the mains and bypass use different power sources, ensure that the neutral wires of the mains and bypass input power sources are equipotential. For example, the mains and bypass inputs are from the same transformer.

Single UPS

The UPS uses a modular design. It uses multiple power modules connected in parallel to deliver a high loading capacity. If one power module is faulty, other power modules continue working. If loads are light, the UPS provides redundant capacity even if only a single UPS is operating, which ensures high reliability.

Figure 1-1 Typical application scenario of a single UPS

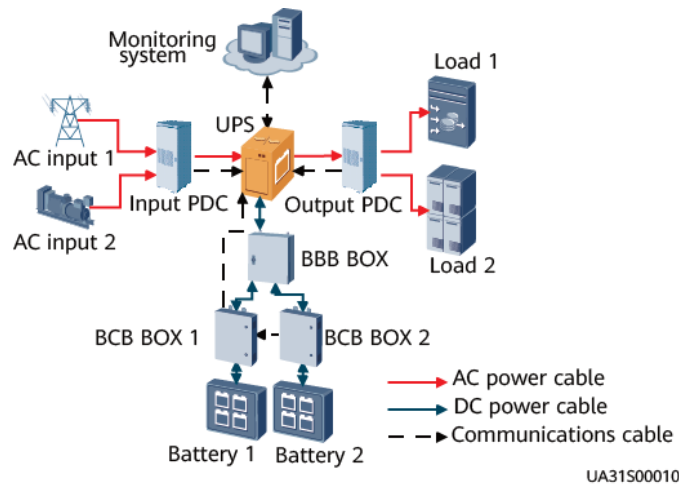

Parallel System

In a parallel system, mains input, bypass input, and AC output terminals of UPSs are connected in parallel. ECMs on different UPSs are connected over parallel cables to synchronize UPS outputs to supply power to loads. If one UPS fails, another UPS continues supplying power to loads, which ensures system reliability.

Figure 1-2 Typical application scenario of 1+1 parallel system

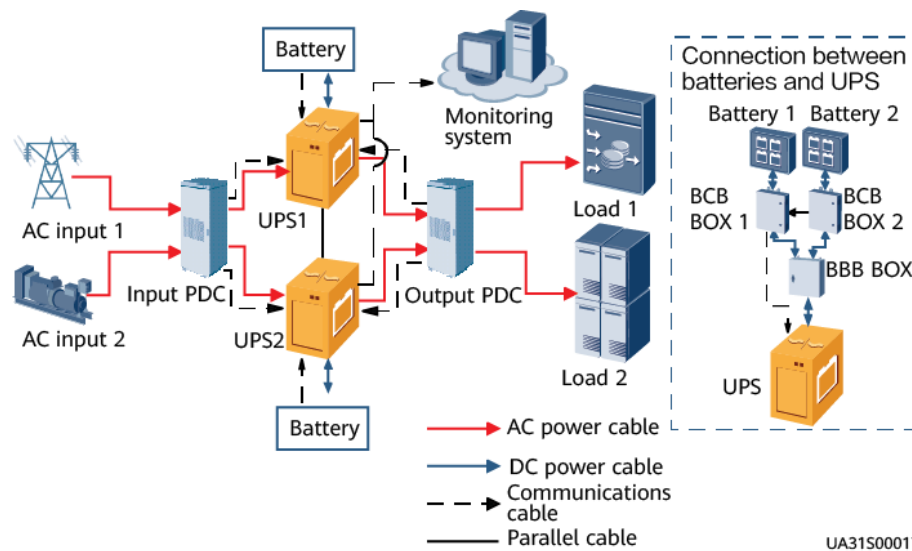

Dual-Bus System

A dual-bus system consists of two independent UPS systems. Each UPS system consists of one UPS or multiple UPSs connected in parallel. Of the two UPS systems, one is the master system and the other is the slave system. The dual-bus system is

highly reliable and is suitable for loads with multiple input terminals. You can install an optional static transfer switch (STS) to start a bus synchronization controller (BSC) provided in standard configuration. The UPS systems work in inverter mode or bypass mode.

Figure 1-3 Typical application scenario of a dual-bus system consisting of single UPS systems

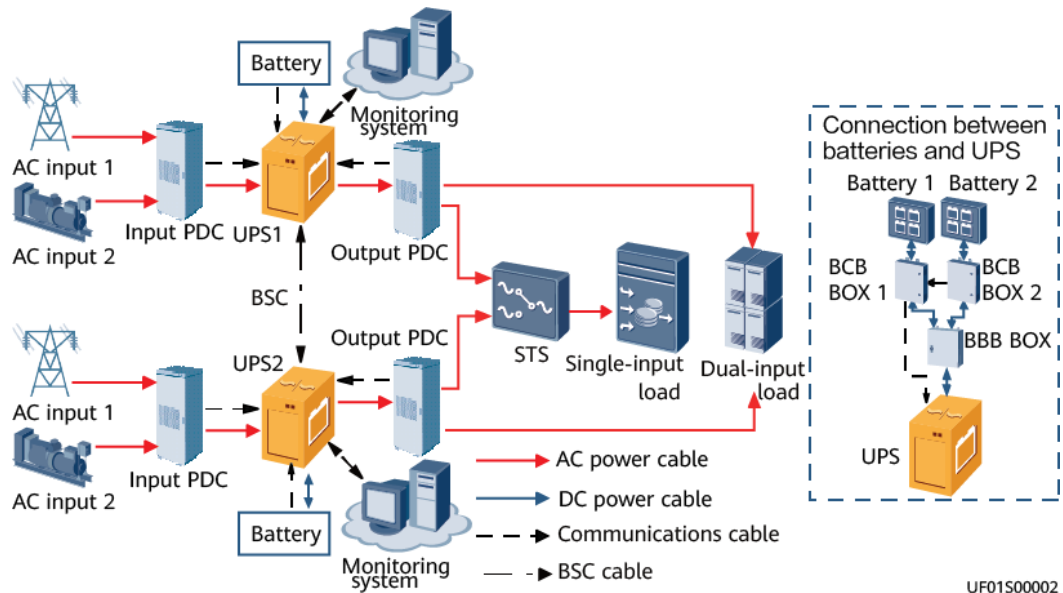

1.4 Working Principle

The UPS is an online product. It uses modular design, which facilitates maintenance and capacity expansion. Intelligent control is adopted for modules. The power module consists of a rectifier, inverter, and DC/DC converter. The product converts inputs into pure high-quality sine wave outputs by using the high-frequency switching technology.

Figure 1-4 Conceptual diagram

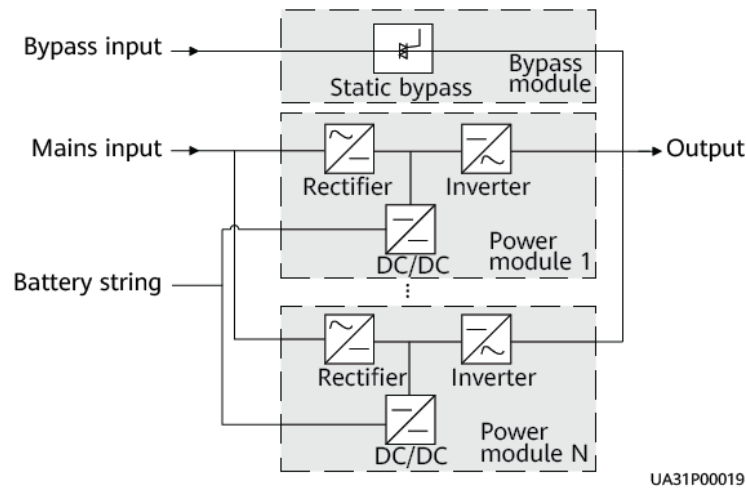

1.5 Working Modes

1.5.1 Normal Mode

In normal mode, the rectifier converts AC power into DC power. Then the inverter converts DC power into AC output. At the same time, the rectifier charges batteries over a charger. The two conversions ensure high-precision and high-quality output voltages, protecting loads from interferences such as input harmonics, glitches, and voltage transients.

Figure 1-5 UPS conceptual diagram in normal mode

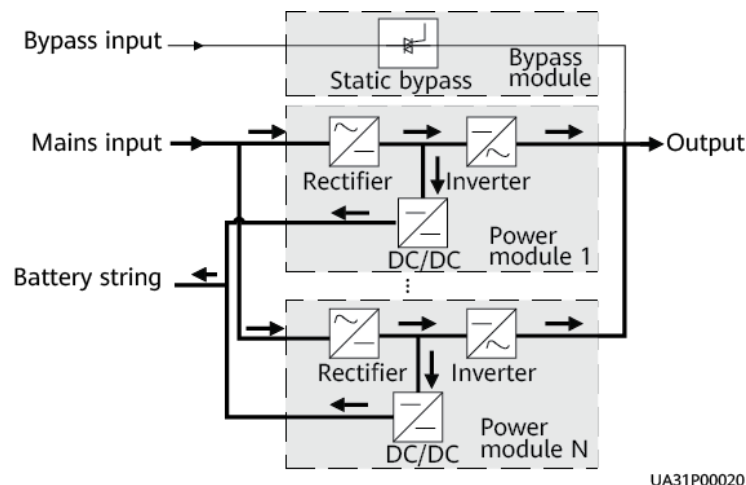

1.5.2 Bypass Mode

When the UPS detects that the power module experiences overtemperature, overload, or other faults that may shut down the inverter, the UPS automatically transfers to bypass mode. At the same time, the rectifier is started and charges batteries over a charger. In bypass mode, loads are powered by the bypass module. The bypass power supply is not protected by the UPS and therefore is prone to the mains outage, abnormal AC voltage waveform, or abnormal frequency.

Figure 1-6 UPS conceptual diagram in bypass mode

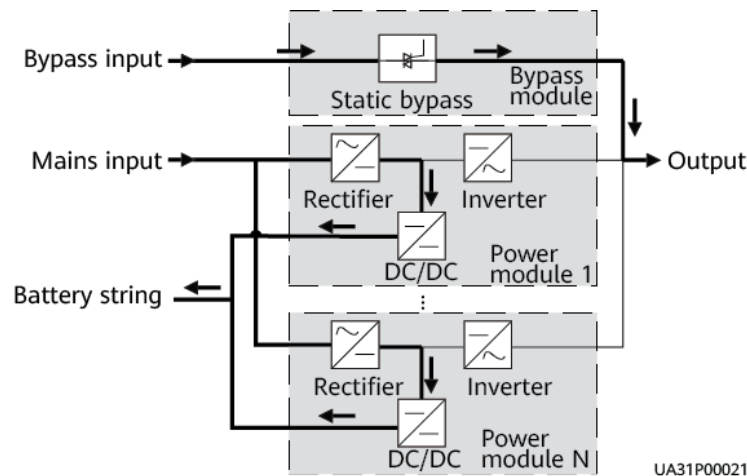

1.5.3 Battery Mode

If the mains input is abnormal or the rectifier becomes abnormal, the UPS transfers to battery mode. The power module obtains energy from batteries, and the energy is converted into AC output by the inverter.

Figure 1-7 UPS conceptual diagram in battery mode

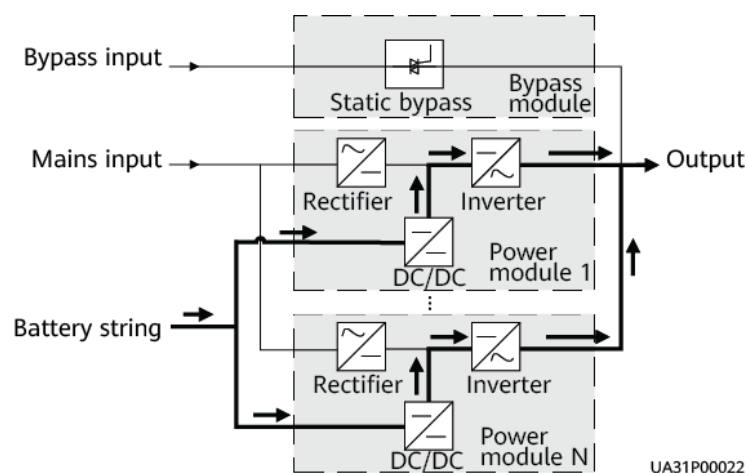

1.5.4 S-ECO Mode

NOTE

- Only the three-phase four-wire 380 V AC/400 V AC/415 V AC (line voltage) model supports the super economy control operation (S-ECO) mode.
- The system can work in S-ECO mode only when the hardware of both the power module and bypass module supports the S-ECO mode.
- If the hardware of the existing power module or bypass module does not support the S-ECO mode, the ECO mode is displayed (2–5 ms interruption may occur during the transfer of this traditional ECO mode). If the UPS works in S-ECO mode but the hardware of the power module or bypass module is changed and does not support the S-ECO mode, a dialog box is displayed, indicating that the hardware does not support the S-ECO mode. After you click **OK**, the UPS works in ECO mode.

S-ECO is a working mode that combines the economy control operation (ECO) mode and inverter mode. In S-ECO mode, the UPS directly supplies power to loads through the bypass and automatically determines whether to compensate for load harmonics based on load conditions to achieve higher efficiency. It ensures uninterruptible (0 ms) power supply and reduces the impact of load harmonics on the power grid. This mode can be set on the LCD or WebUI.

- When the bypass input voltage waveform is good (the voltage and frequency are within the preset bypass range, the PF is greater than 0.5, and the load rate is greater than 15%), the UPS works in bypass mode preferentially and the inverter starts for hot backup to achieve 0 ms transfer. When the load harmonic is greater than the preset value, the inverter output compensates for the harmonic component in the load.
- If the bypass input voltage waveform is poor (the voltage and frequency exceed the preset bypass range, the PF is less than 0.5, or the load rate is less than 15%), the UPS works in inverter mode preferentially.
- In either bypass mode or inverter mode, the rectifier is started all the time and charges batteries using a charger.

Figure 1-8 UPS conceptual diagram in S-ECO mode

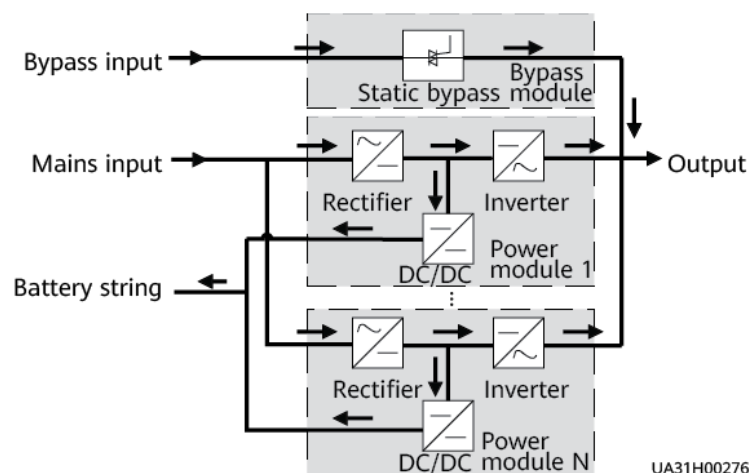

NOTE

Manual startup is required to ensure that the inverter is in standby state and the power flow has reached the load side through the inverter.

1.5.5 ECO Mode (The System Can Work in ECO Mode If the Model or Hardware Does Not Support S-ECO)

The ECO mode is an economy working mode, which can be configured on the LCD or web user interface (WebUI). In ECO mode, when the bypass input is within the ECO voltage and frequency ranges and other ECO power supply conditions are met, the UPS works in bypass mode and the inverter is in standby state. When the bypass source voltage is outside the ECO voltage range, the UPS transfers from bypass mode to inverter mode. In either bypass mode or inverter mode, the rectifier is started all the time and charges batteries using a charger. The ECO mode delivers a high efficiency.

Figure 1-9 UPS conceptual diagram in ECO mode

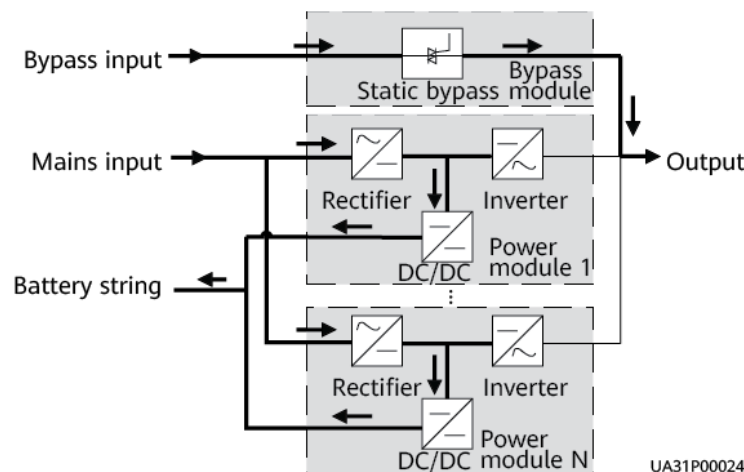

NOTE

Manual startup is required to ensure that the inverter is in standby state and the power flow has reached the inverter.

1.5.6 Source-Share Mode

If the UPS works properly and the AC input power of rectifiers is insufficient, the UPS transfers to source-share mode. In this case, the power module obtains energy from both the mains and batteries, and the energy is converted into AC outputs by the inverter.

Figure 1-10 Conceptual diagram in source-share mode

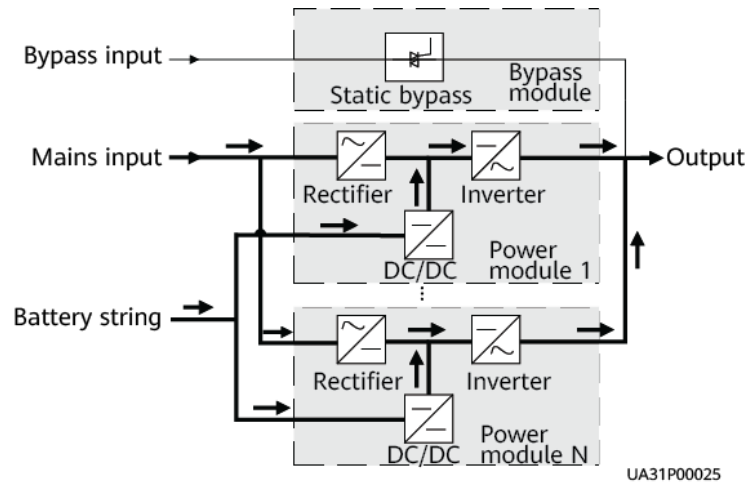

2 Product Description

2.1 Model Description (Three-Phase Four-Wire)

Figure 2-1 Model number (1200K is used as an example)

UPS5000-H-1200K-NT

1 2 3 4 5

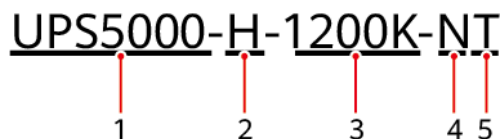

Table 2-1 Model description

No.	Item	Description
1	Product category	UPS5000
2	Product subcategory	H: high power density and high efficiency
3	Rated capacity	<ul style="list-style-type: none">1200K: output capacity of 1200 kVA in full configuration (supports a minimum of 200 kVA. This document describes only the specifications of the 1200 kVA model.)1600 kVA: output capacity of 1600 kVA in full configuration (supports a minimum of 200 kVA. This document describes only the specifications of the 1600 kVA model.)
4	Switch configuration	N: no switch

No.	Item	Description
5	Cabling	<p>T: Cables are routed in and out from the top.</p> <p>NOTE</p> <ul style="list-style-type: none"> If the system is not configured with optional components, battery cables can be routed in and out from the top, and input and output cables can be connected using the busway. If the system is configured with a top cabling component, cables can be routed in and out from the top. If the system is configured with a bottom cabling cabinet, cables can be routed in and out from the bottom.

2.2 Model Description (Three-Phase Three-Wire)

Figure 2-2 Model number (1200K is used as an example)

UPS5000-H-1200K-NTN

1 2 3 4 5 6

Table 2-2 Model description

No.	Item	Description
1	Product category	UPS5000
2	Product subcategory	H: high power density and high efficiency
3	Rated capacity	<ul style="list-style-type: none"> 1200K: output capacity of 1200 kVA in full configuration (supports a minimum of 200 kVA. This document describes only the specifications of the 1200 kVA model.) 1600 kVA: output capacity of 1600 kVA in full configuration (supports a minimum of 200 kVA. This document describes only the specifications of the 1600 kVA model.)
4	Switch configuration	N: no switch

No.	Item	Description
5	Cabling	T: Cables are routed in and out from the top. NOTE <ul style="list-style-type: none">• If the system is not configured with optional components, battery cables can be routed in and out from the top, and input and output cables can be connected using the busway.• If the system is configured with a top cabling component, cables can be routed in and out from the top.• If the system is configured with a bottom cabling cabinet, cables can be routed in and out from the bottom.
6	Configuration type	N: no neutral wire

2.3 Cabinet Description (1200 kVA, Three-Phase Four-Wire)

2.3.1 Standard Configuration

Figure 2-3 UPS exterior



Figure 2-4 UPS interior

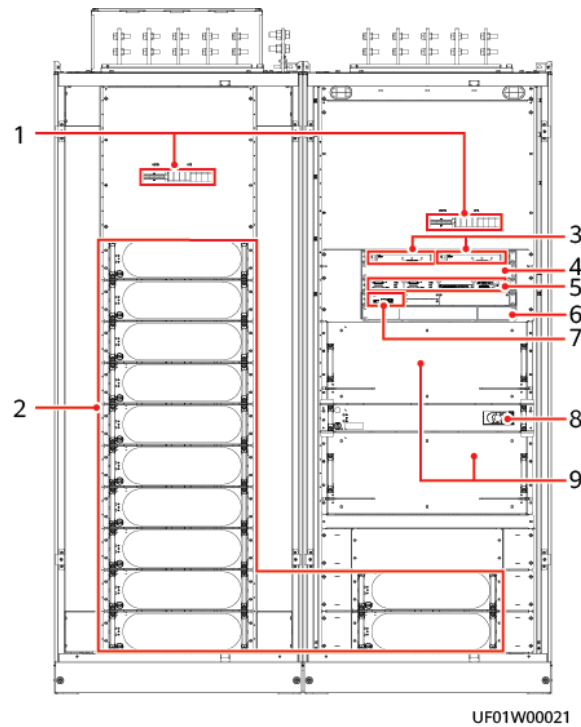

- | | | |
|---------------------------------------------------------|---------------------------|-----------------------------|
| (1) SPDs and SPD switches | (2) Power modules | (3) Surge protection boxes |
| (4) Filler panel (for an optional ECM extended subrack) | (5) Control module | (6) Filler panel (optional) |
| (7) Intelligent detection card | (8) Bypass control module | (9) Bypass modules |

2.3.2 Top Cabling Configuration

Figure 2-5 Appearance

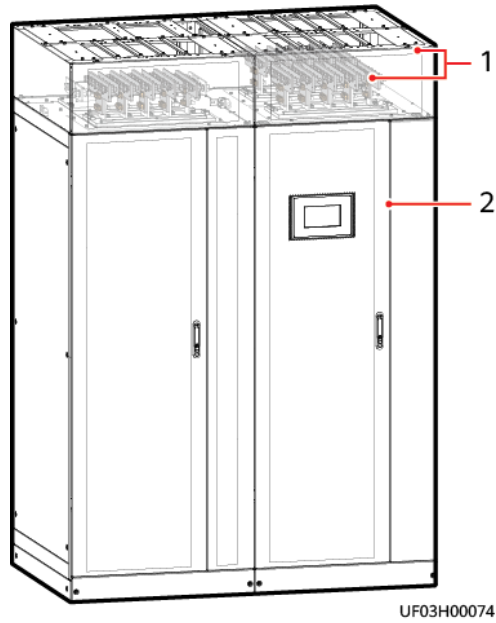

(1) Top cabling component (optional, including the top frame and transfer copper bar)

(2)
UPS

2.3.3 Bottom Cabling Configuration

Figure 2-6 Appearance

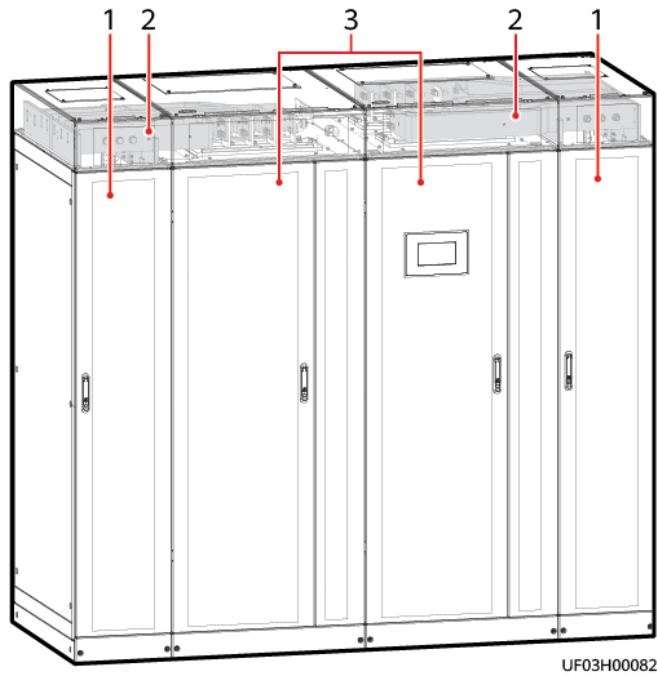

(1) Bottom cabling cabinet (optional, including the top frame)

(2) Transfer copper bar for bottom cabling (optional)

(3) UPS

2.3.4 Top Air-Flow Configuration

Figure 2-7 Appearance

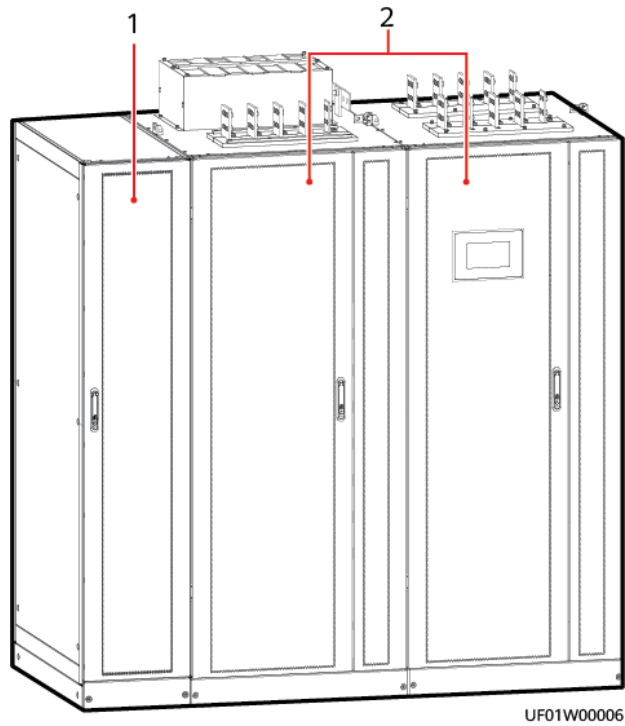

(1) Top air-flow cabinet (optional)

(2) UPS

2.3.5 Top Air-Flow + Top Cabling Configuration

Figure 2-8 Appearance

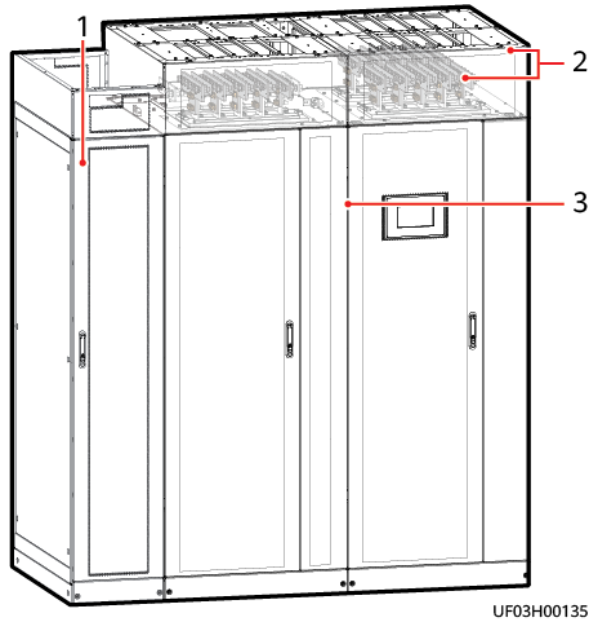

(1) Top air-flow cabinet (optional)

(2) Top cabling component (optional, including the top frame and transfer copper bar)

(3) UPS

2.4 Cabinet Description (1200 kVA, Three-Phase Three-Wire)

2.4.1 Standard Configuration

Figure 2-9 Exterior

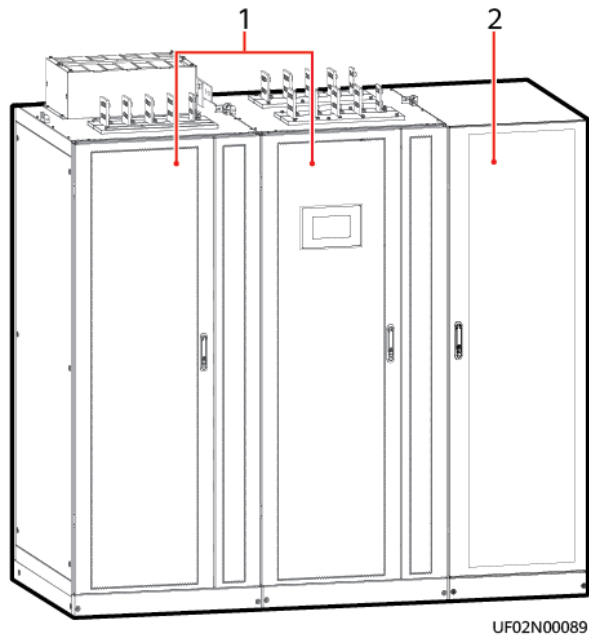

UF02N00089

(1) UPS

(2) Inductor cabinet

Figure 2-10 Interior

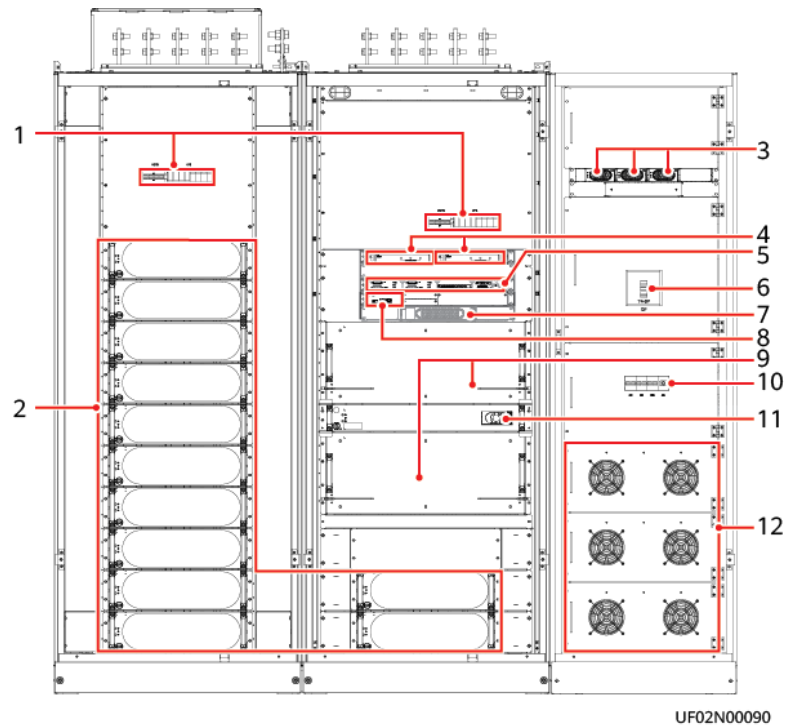

- UF02N00090
- | | | |
|------------------------------------------------|--------------------------------|--------------------------------------------|
| (1) SPDs and SPD switches | (2) Power modules | (3) Rectifiers |
| (4) Surge protection boxes | (5) Control module | (6) Main switch QF of the inductor cabinet |
| (7) Bypass fan PSU | (8) Intelligent detection card | (9) Bypass modules |
| (10) Inductor cabinet fan power switches QS1-4 | (11) Bypass control module | (12) Fans |

2.4.2 Top Cabling Configuration

Figure 2-11 Appearance

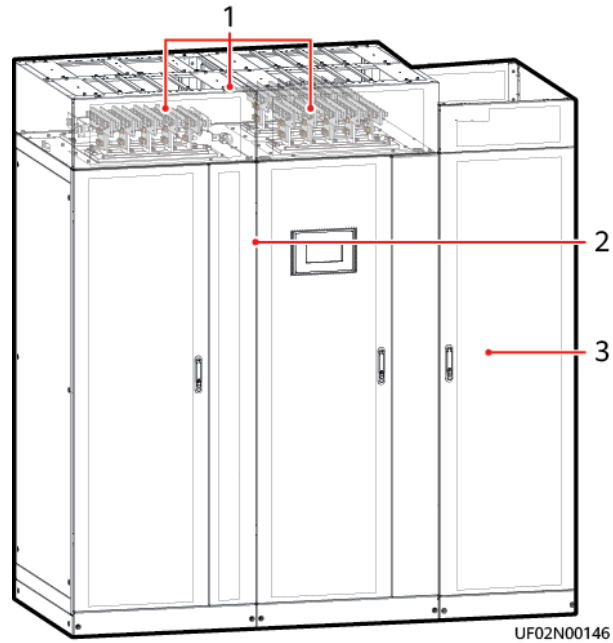

(1) Top cabling component (optional, including the top frame and transfer copper bar)

(2) UPS

(3) Inductor cabinet

2.4.3 Bottom Cabling Configuration

Figure 2-12 Appearance

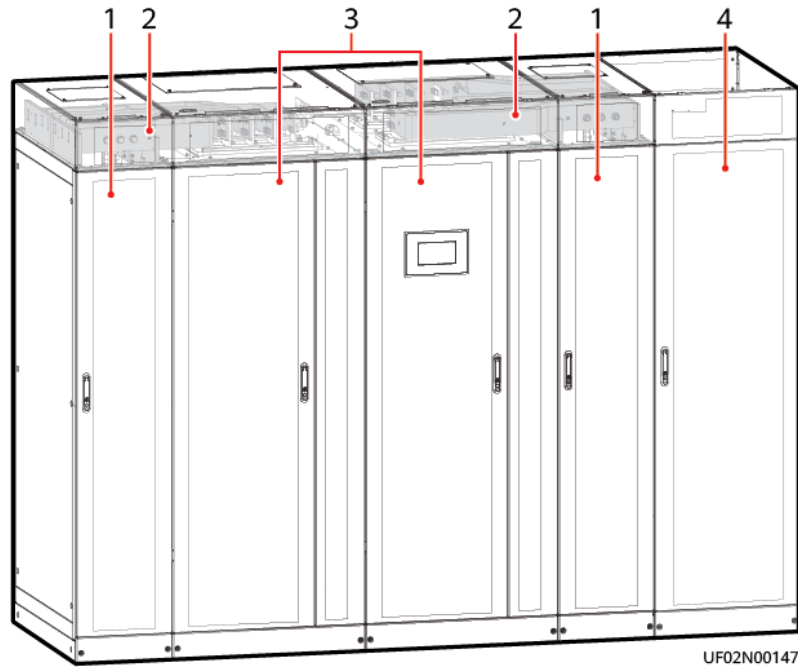

(1) Bottom cabling cabinet (optional, including the top frame)

(3) UPS

(2) Transfer copper bar for bottom cabling (optional)

(4) Inductor cabinet

2.4.4 Top Air-Flow Configuration

Figure 2-13 Appearance

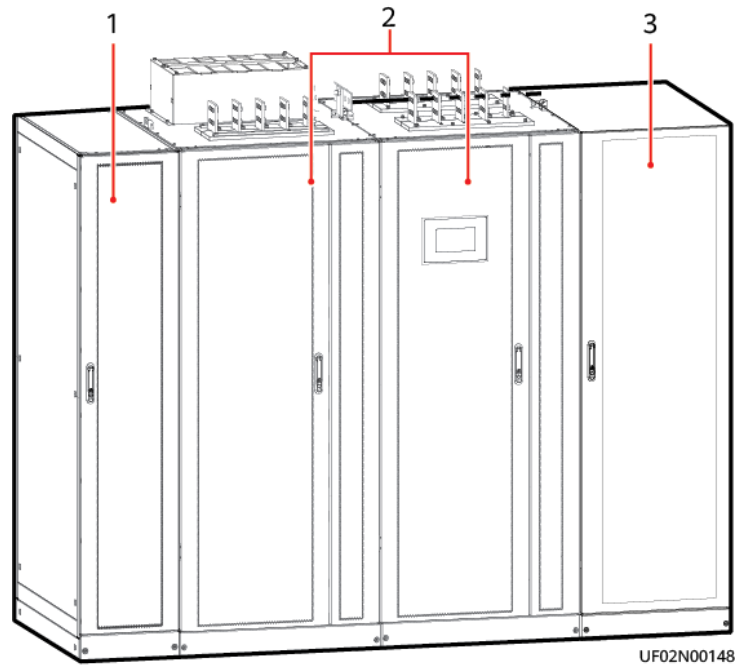

(1) Top air-flow cabinet (optional)

(2) UPS

(3) Inductor cabinet

2.4.5 Top Air-Flow + Top Cabling Configuration

Figure 2-14 Appearance

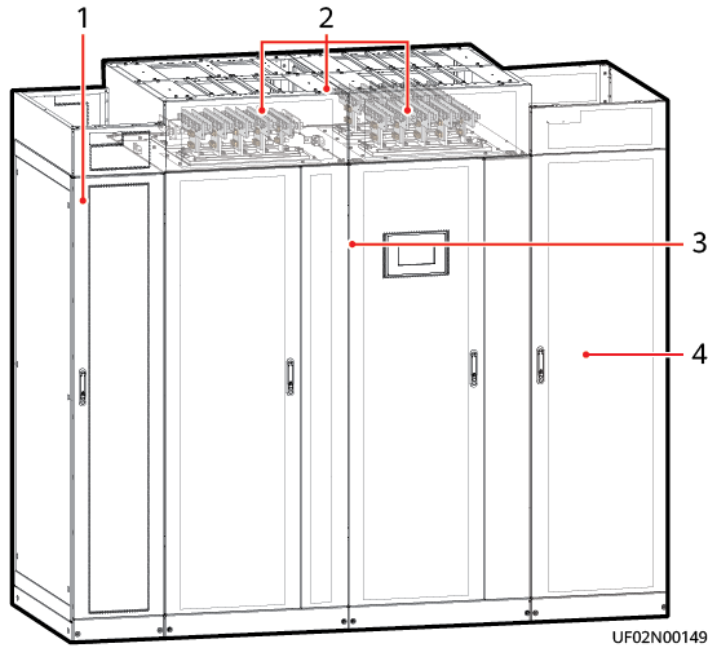

- (1) Top air-flow cabinet (optional)
- (2) Top cabling component (optional, including the top frame and transfer copper bar)
- (3) UPS
- (4) Inductor cabinet

2.5 Cabinet Description (1600 kVA, Three-Phase Four-Wire)

2.5.1 Standard Configuration

Figure 2-15 UPS exterior

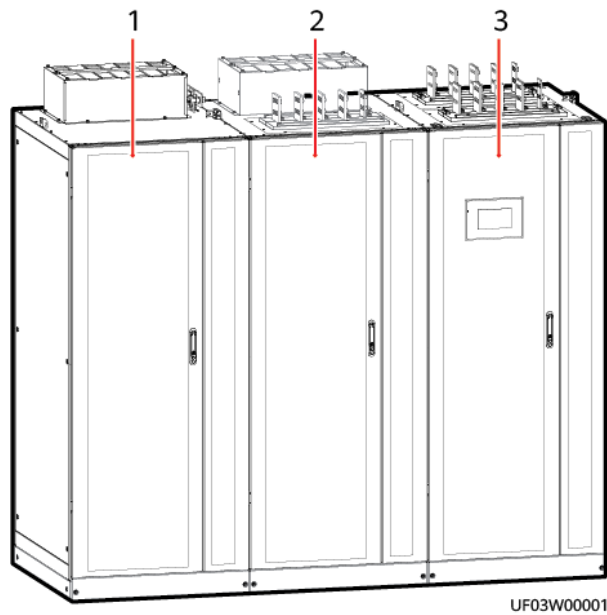

UF03W00001

(1) Power cabinet 1

(2) Power cabinet 2

(3) Bypass cabinet

Figure 2-16 UPS structure with the door open

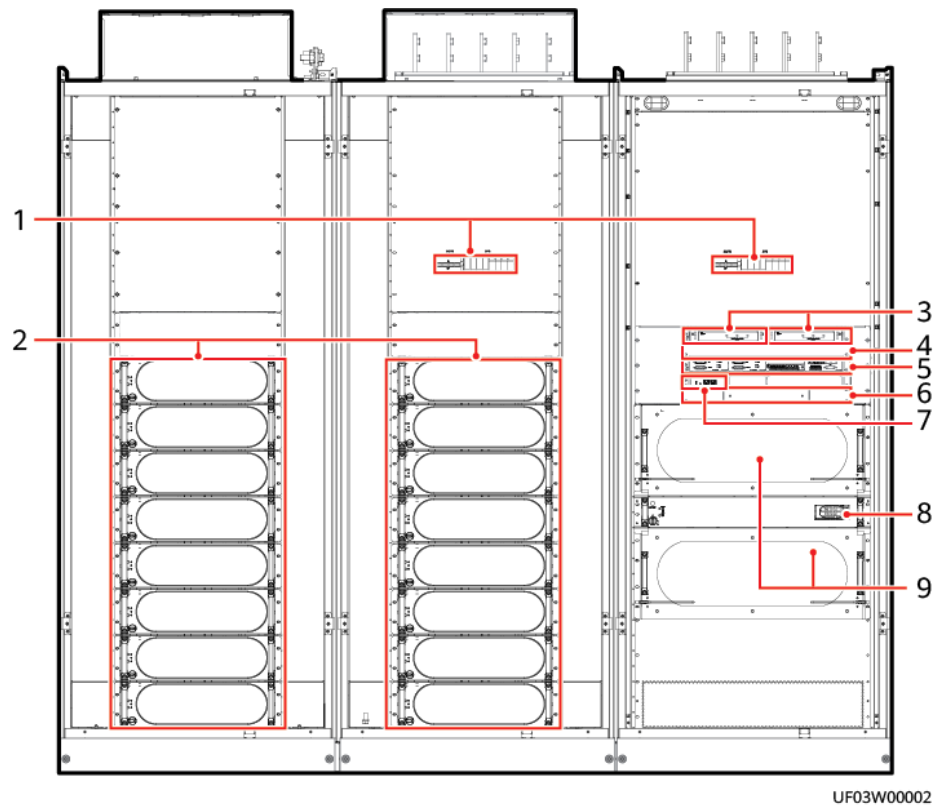

- | | | |
|---------------------------------------------------------|---------------------------|-----------------------------|
| (1) SPDs and SPD switches | (2) Power modules | (3) Surge protection boxes |
| (4) Filler panel (for an optional ECM extended subrack) | (5) Control module | (6) Filler panel (optional) |
| (7) Intelligent detection card | (8) Bypass control module | (9) Bypass modules |

2.5.2 Top Cabling Configuration

Figure 2-17 UPS + top cabling component

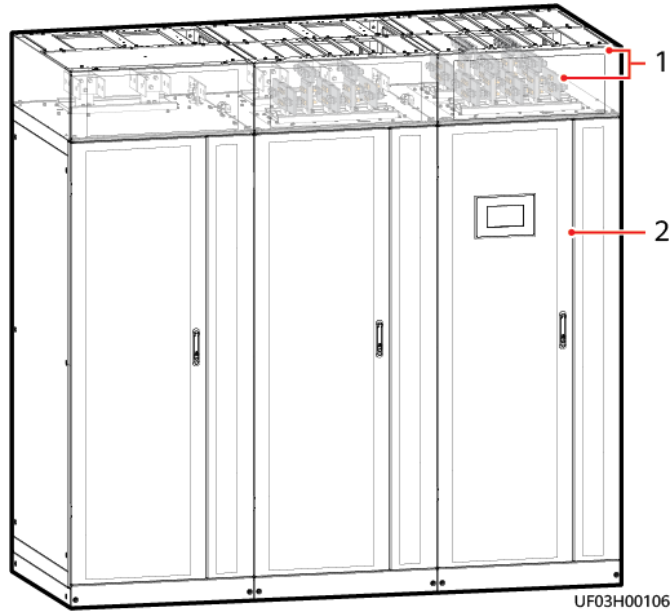

(1) Top cabling component (optional, including the top frame and transfer copper bar)

(2)
UPS

2.5.3 Bottom Cabling Configuration

Figure 2-18 UPS + bottom cabling cabinet

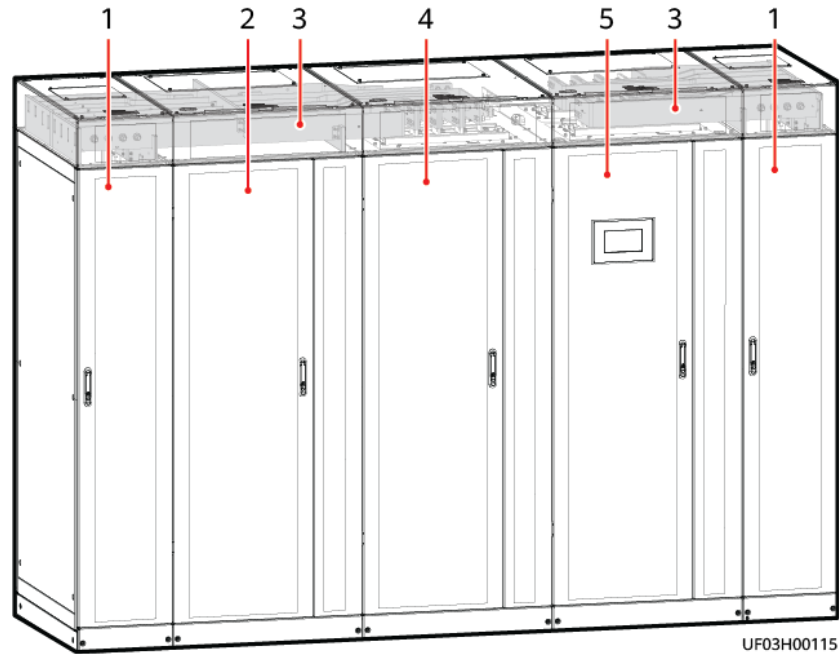

(1) Bottom cabling cabinet
(optional, including the top
frame)

(4) Power cabinet 2

(2) Power
cabinet 1

(5) Bypass
cabinet

(3) Transfer copper bar for
bottom cabling (optional)

2.5.4 Top Air-Flow Configuration

Figure 2-19 UPS + top air-flow cabinet

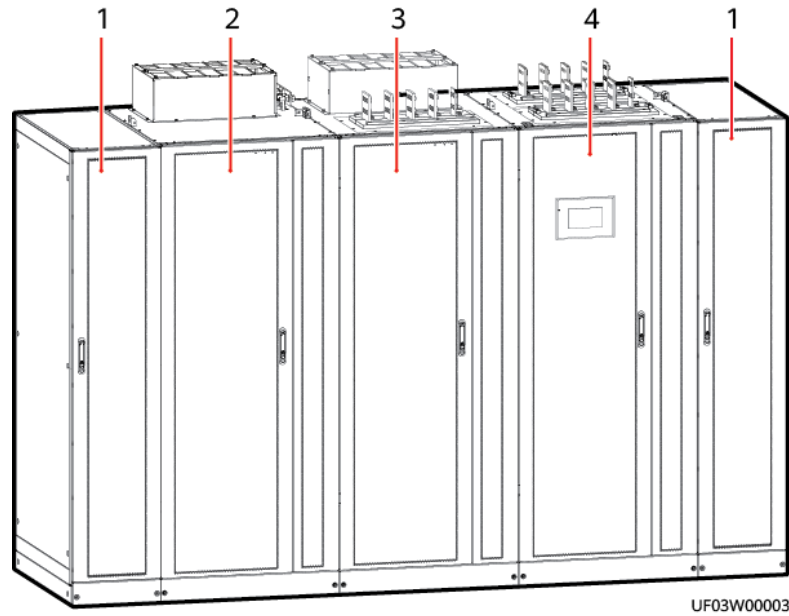

(1) Top air-flow cabinet
(optional)

(2) Power
cabinet 1

(3) Power
cabinet 2

(4) Bypass
cabinet

2.5.5 Top Air-Flow + Top Cabling Configuration

Figure 2-20 UPS + top cabling component + top air-flow cabinet

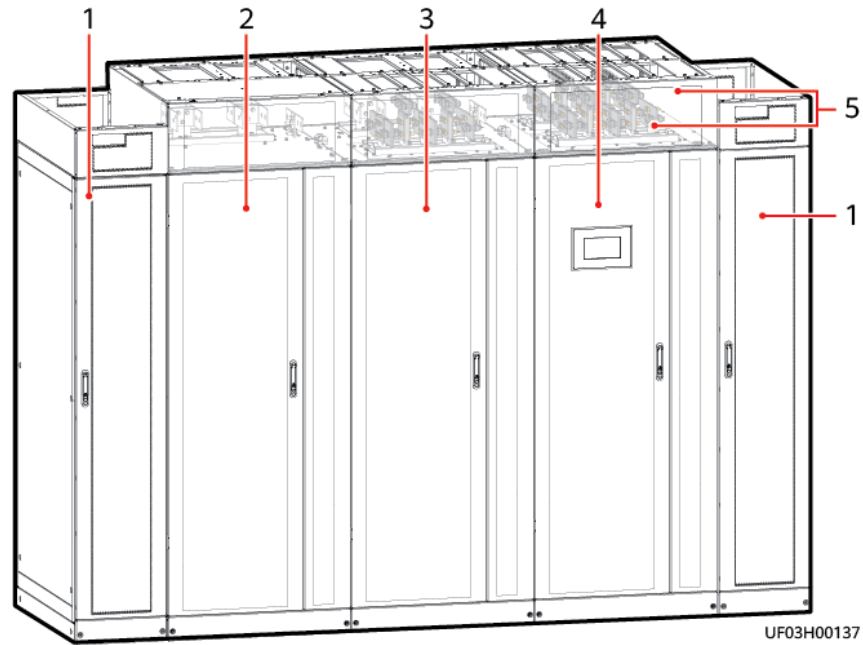

(1) Top air-flow cabinet (optional)

(2) Power cabinet 1

(3) Power cabinet 2

(4) Bypass cabinet

(5) Top cabling component (optional, including the top frame and transfer copper bar)

2.6 Cabinet Description (1600 kVA, Three-Phase Three-Wire)

2.6.1 Standard Configuration

Figure 2-21 Appearance

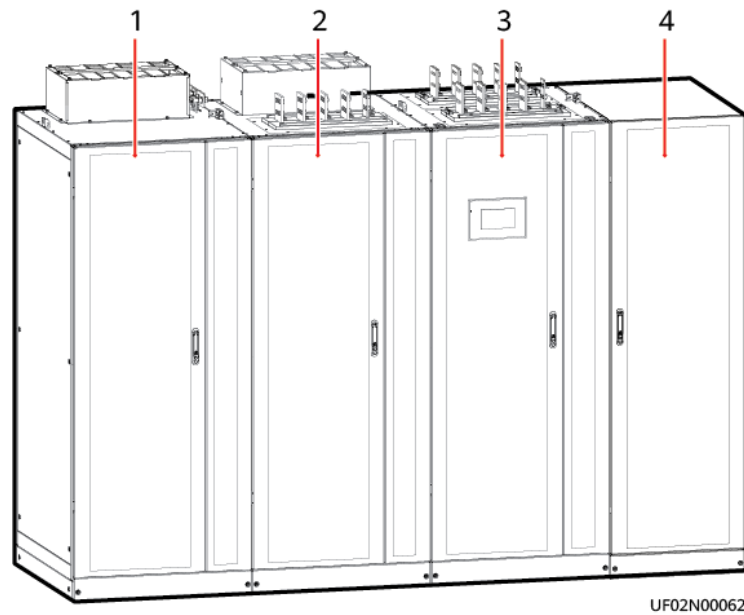

(1) Power cabinet
1

(2) Power cabinet
2

(3) Bypass
cabinet

(4) Inductor
cabinet

Figure 2-22 Structure with the door open

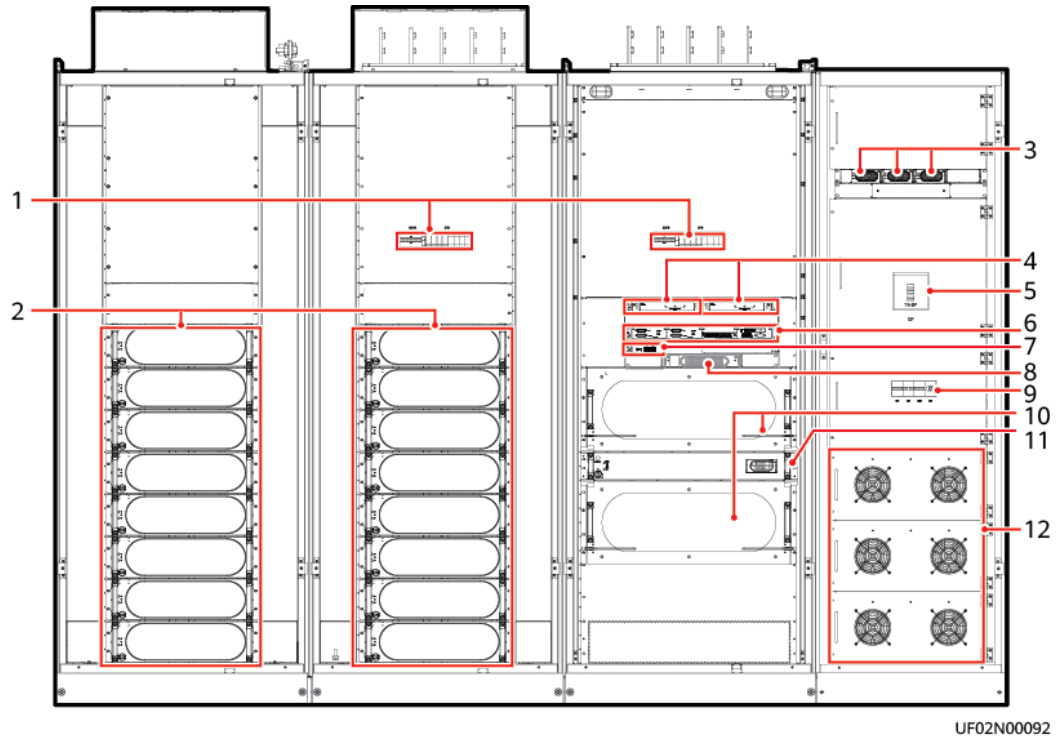

- | | | |
|--------------------------------|--------------------------------------------|-----------------------------------------------|
| (1) SPDs and SPD switches | (2) Power modules | (3) Rectifiers |
| (4) Surge protection boxes | (5) Main switch QF of the inductor cabinet | (6) Control module |
| (7) Intelligent detection card | (8) Bypass fan PSU | (9) Inductor cabinet fan power switches QS1-4 |
| (10) Bypass modules | (11) Bypass control module | (12) Fans |

2.6.2 Top Cabling Configuration

Figure 2-23 Appearance

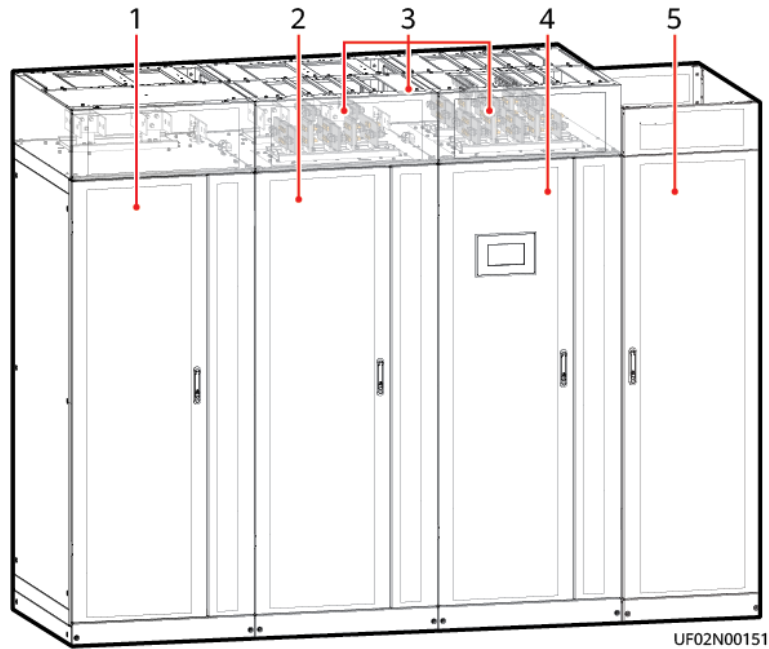

(1) Power cabinet 1

(2) Power cabinet 2

(3) Top cabling component (optional, including the top frame and transfer copper bar)

(4) Bypass cabinet

(5) Inductor cabinet

2.6.3 Bottom Cabling Configuration

Figure 2-24 Appearance

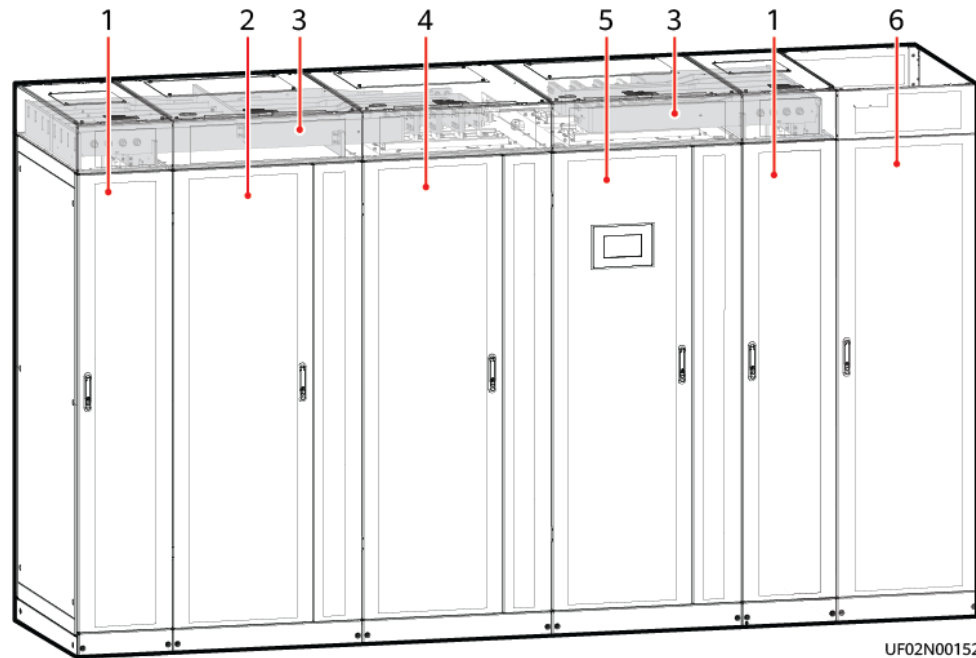

(1) Bottom cabling cabinet
(optional, including the top
frame)

(4) Power cabinet 2

(2) Power
cabinet 1

(5) Bypass
cabinet

(3) Transfer copper bar for
bottom cabling (optional)

(6) Inductor cabinet

2.6.4 Top Air-Flow Configuration

Figure 2-25 Appearance

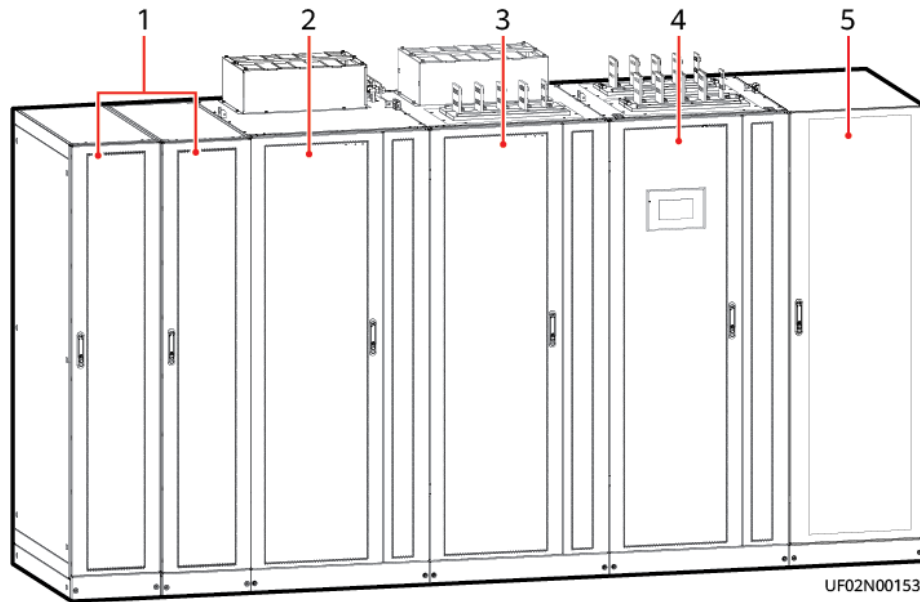

- (1) Top air-flow cabinet (optional) (2) Power cabinet 1 (3) Power cabinet 2
(4) Bypass cabinet (5) Inductor cabinet

2.6.5 Top Air-Flow + Top Cabling Configuration

Figure 2-26 Appearance

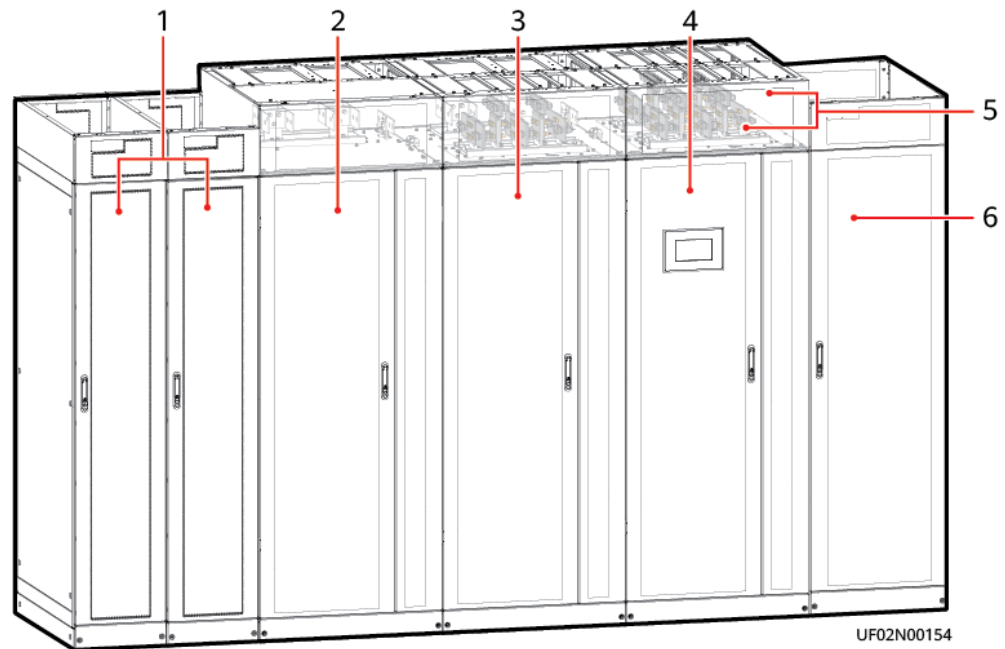

(1) Top air-flow cabinet (optional)

(2) Power cabinet 1

(3) Power cabinet 2

(4) Bypass cabinet

(5) Top cabling component (optional, including the top frame and transfer copper bar)

(6) Inductor cabinet

3 Component Description

3.1 Power Module

The power module consists of a power factor correction (PFC) rectifier and inverter. It performs AC/DC or DC/DC conversion on the mains and battery inputs, and stabilizes the bus voltage. The inverter (DC/AC) converts the inputs into sine wave outputs.

Figure 3-1 Appearance

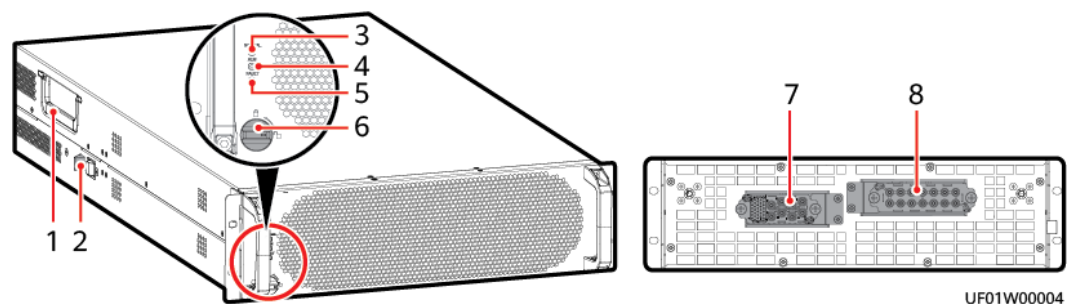

- | | | | |
|---------------------|----------------------|-----------------------|---------------------|
| (1) Handle | (2) Positioning lock | (3) Running indicator | (4) Alarm indicator |
| (5) Fault indicator | (6) Ready switch | (7) Output ports | (8) Input ports |

Table 3-1 Indicator description

Indicator	Color	Status	Description
Running	Green	Steady on	The system is working in inverter mode.

Indicator	Color	Status	Description
indicator		Blinking at long intervals	<ul style="list-style-type: none"> The inverter is ready and in standby state (blinking at 0.5 Hz, on for 1s and off for 1s). The inverter is not started (blinking at 0.2 Hz, on for 2.5s and off for 2.5s).
		Blinking at short intervals	The module is not configured, the inverter software and rectifier software are being upgraded, or the inverter software is being upgraded (blinking at 4 Hz, on for 0.125s and off for 0.125s).
		Off	The software is being upgraded.
Alarm indicator	Yellow	Steady on	A minor alarm is generated for the inverter or rectifier.
		Off	There is no minor alarm for the inverter or rectifier, or the software is being upgraded.
Fault indicator	Red	Steady on	A critical alarm is generated for the inverter or rectifier.
		Off	There is no critical alarm for the inverter or rectifier, or the software is being upgraded.

Table 3-2 Specifications

Item	Specifications
Rated output capacity	100 kVA/100 kW
Dimensions (H x W x D)	130 mm x 442 mm x 750 mm
Weight	< 55 kg

3.2 Bypass Module

The UPS works in bypass mode under the following circumstances:

- The S-ECO or ECO mode is used and the bypass voltage is within the specified range.
- The power module overload times out.
- Both active and standby energy control modules (ECMs) in the system are abnormal.
- The system runs abnormally.
- The UPS is transferred to bypass mode manually.

Figure 3-2 Appearance

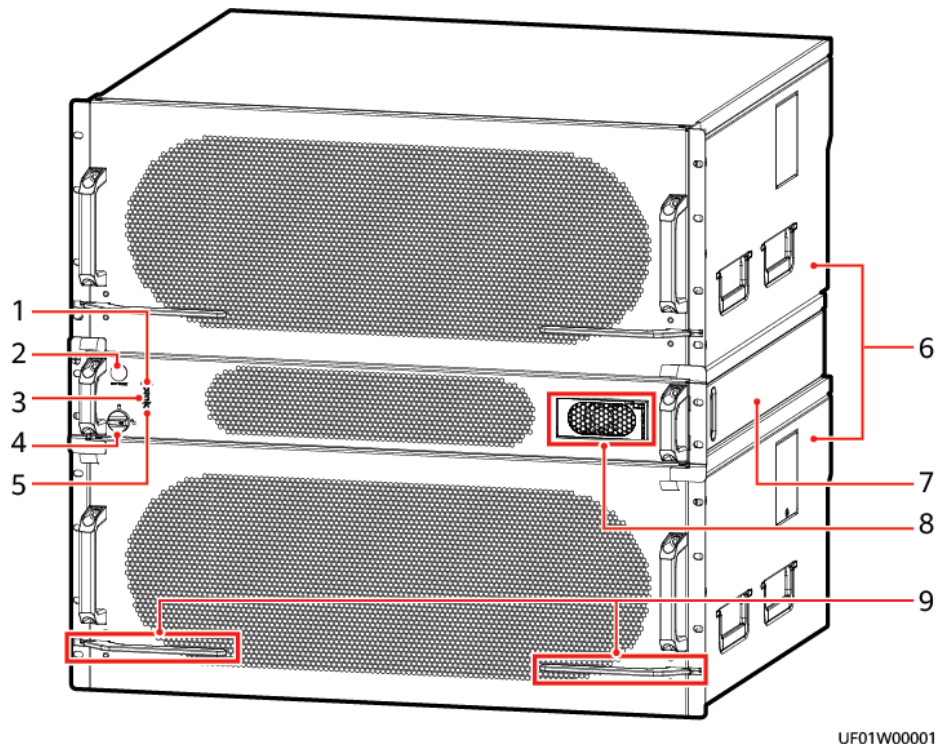

UF01W00001

- | | | |
|---------------------------|-------------------------------|---------------------|
| (1) Running indicator | (2) Battery cold start button | (3) Alarm indicator |
| (4) Ready switch | (5) Fault indicator | (6) Bypass modules |
| (7) Bypass control module | (8) Auxiliary power supply | (9) Crowbar |

Table 3-3 Indicator description

Indicator	Color	Status	Description
Running indicator	Green	Steady on	The system is working in bypass mode.
		Blinking slowly	The bypass has no output (blinking at 0.2 Hz, on for 2.5s and off for 2.5s).

Indicator	Color	Status	Description
		Blinking fast	The bypass is not configured or the software is being upgraded (blinking at 4 Hz, on for 0.125s and off for 0.125s).
		Off	The bypass software is being upgraded.
Alarm indicator	Yellow	Steady on	A minor alarm is generated for the bypass.
		Off	There is no minor alarm for the bypass, or the software is being upgraded.
Fault indicator	Red	Steady on	A critical alarm is generated for the bypass.
		Off	There is no critical alarm for the bypass, or the software is being upgraded.

Table 3-4 Specifications

Item	Bypass Module	Bypass Control Module
Dimensions (H x W x D)	263.5 mm x 642 mm x 668 mm	86.1 mm x 642 mm x 600 mm
Weight	< 90 kg	< 16 kg

3.3 Control Module

3.3.1 Overview

The control module in a standard configuration contains two ECMs, one dry contact card, and one monitoring interface card from left to right. The four cards are hot-swappable. One subrack is reserved above the dry contact card. A backfeed protection card or dry contact extended card can be inserted into the subrack.

Figure 3-3 Signal panel of the control module

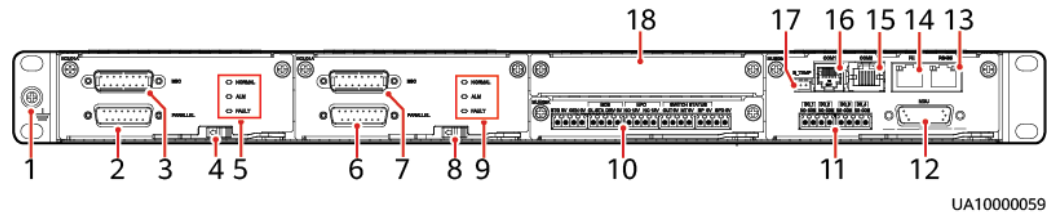

UA10000059

- | | | | |
|--------------------------------------|----------------------------------|-------------------|-----------------------------------------|
| (1) Ground terminal | (2) Parallel port 1 | (3) BSC port 1 | (4) Ready switch on ECM 1 |
| (5) ECM 1 indicators | (6) Parallel port 2 | (7) BSC port 2 | (8) Ready switch on ECM 2 |
| (9) ECM 2 indicators | (10) Dry contact card | (11) Dry contacts | (12) Monitoring display unit (MDU) port |
| (13) RS485 port | (14) FE port | (15) COM2 | (16) COM1 port |
| (17) Battery temperature sensor port | (18) Optional card subrack cover | | |

NOTE

Ports are protected by a security mechanism.

3.3.2 ECM

- As a control interface for the entire system, the ECM communicates with each module and provides a bus for communication between the dry contact card and the system control card. The ECM ensures equalized output currents between modules so that load power is equally shared.
- The ECM provides module working status information to the monitoring system.
- The ECM controls the running of a single UPS and a parallel system, and reports the UPS status information to other monitoring modules.
- The system provides three types of CAN communication: monitoring CAN communication, intra-rack parallel CAN communication, and inter-rack parallel CAN communication.
- The control module consists of one active ECM and one standby ECM.
- Hot-swappable, 1 U high.

Figure 3-4 Appearance

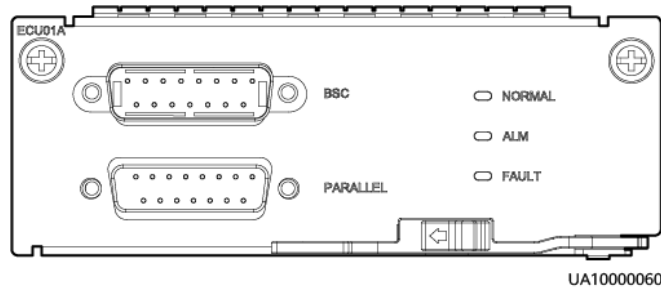

Table 3-5 Port description

Silk Screen	Description
PARALLEL	The PARALLEL port transmits parallel signals between racks.
BSC	The BSC port is used in a dual-bus system to synchronize output frequencies and phases between UPS systems, ensuring that two buses can switch with each other. BSC cables are hot-swappable.

NOTE

No parallel cable is required for a single UPS.

Table 3-6 Indicator description

Indicator	Color	Status	Description
NORMAL	Green	Steady on	This ECM is the active ECM.
		Blinking at 0.5 Hz	This ECM is the standby ECM and it is ready.
		Off	This ECM is not ready or the software of this ECM is being upgraded.
		Blinking at 4 Hz	The ECM software is being upgraded or not configured.
ALM	Yellow	Steady on	The ECM has a minor alarm, but it does not need to be replaced.
		Off	The ECM has no minor alarm or the software of the ECM is being upgraded.
FAULT	Red	Steady on	The ECM has a critical alarm.

Indicator	Color	Status	Description
		Off	The ECM has no critical alarm or the software of the ECM is being upgraded.

Figure 3-5 CAN communication logic

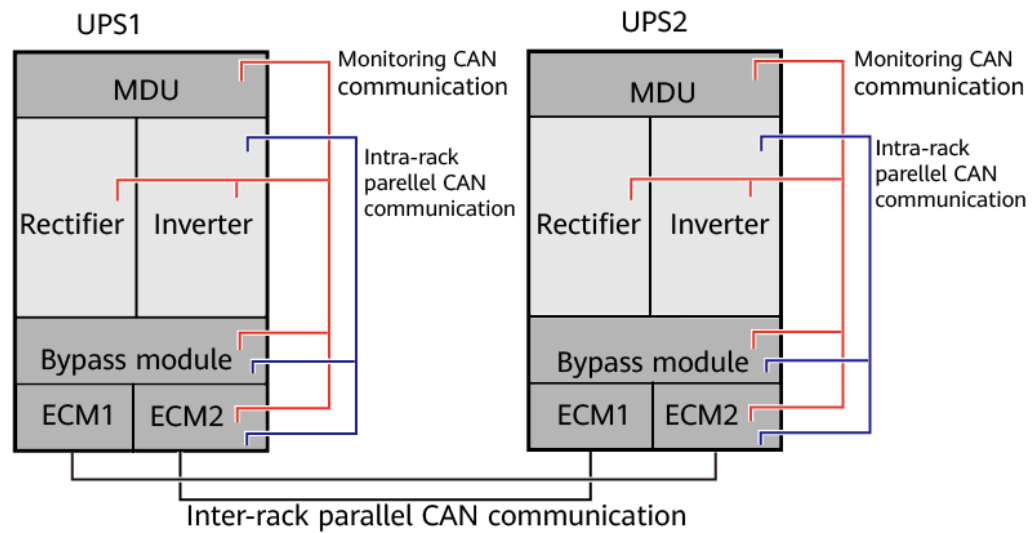

UA31500016

3.3.3 Dry Contact Card

The dry contact card allows the UPS to detect and manage the switch status of the battery system (including the external battery switch) and implement remote emergency power off (EPO). The dry contact card is 0.5 U high and hot-swappable.

NOTICE

- A dry contact card port takes effect only after you set it in the software. You need to disable unused dry contact signals.
- Set the EPO port to normally open (NO) or normally closed (NC) as required.
- If multiple UPSs are connected in parallel, connect all used dry contact signals to each UPS.
- Signal cables must be double-insulated twisted cables. If the cable length is within 25–50 m, the cross-sectional area must be 0.5–1.5 mm².
- For dry contact outputs, the rated DC voltage and current are 24 V DC and 0.6 A and the maximum values are 30 V DC and 1.0 A. The rated AC voltage and current are 24 V AC and 0.6 A and the maximum values are 30 V AC and 1.0 A. During cable connection, ensure that the voltage and current do not exceed these maximum values.

Figure 3-6 Appearance

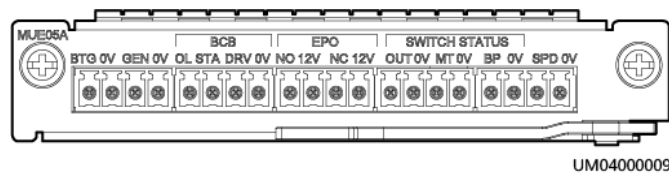

Table 3-7 Functions of control signal ports on the dry contact card

Silk Screen	Signal Description	Status Description	Initial Status
BTG	Port for monitoring battery grounding failures	<ul style="list-style-type: none"> • Closed: There is a battery grounding failure. • Open: There is no battery grounding failure. 	Open ^a
0V	Port for signal ground		
GEN	Port for detecting the diesel generator (DG) mode	<ul style="list-style-type: none"> • Closed: DG mode • Open: non-DG mode 	Open ^a
0V	Port for signal ground		

Silk Screen	Signal Description	Status Description	Initial Status
BCB_OL	Port for monitoring the battery circuit breaker (BCB) box	<ul style="list-style-type: none"> • Grounded: BCB box connected • Disconnected: BCB box not connected 	Grounded
BCB_STA	Port for monitoring the BCB	<ul style="list-style-type: none"> • Closed: The BCB is ON. • Open: The BCB is OFF. 	Open
BCB_DRV	Port for controlling BCB trip. When the voltage is +12 V, the BCB trips.	<ul style="list-style-type: none"> • 0 V: BCB not tripped • 12 V: BCB tripped 	0 V
BCB_0V	Port for signal ground		
EPO_NO	If the NO port is connected to the EPO_12V port, EPO is triggered.	Closing the EPO port triggers EPO.	Open
EPO_12V	+12 V		
EPO_NC	If the NC port is disconnected from the EPO_12V port, EPO is triggered.	Opening the EPO port triggers EPO.	Closed
EPO_12V	+12 V		
SWITCH STATUS_OUT	Port for monitoring the UPS output circuit breaker	<ul style="list-style-type: none"> • Closed: The UPS output circuit breaker is ON. • Open: The UPS output circuit breaker is OFF. 	Closed ^a
SWITCH STATUS_0V	Port for signal ground		
SWITCH STATUS_MT	Port for monitoring the maintenance switch	<ul style="list-style-type: none"> • Open: The maintenance switch is ON. • Closed: The maintenance switch is OFF. 	Open ^a
SWITCH STATUS_0V	Port for signal ground		
SWITCH STATUS_BP	Port for monitoring the bypass input circuit breaker	<ul style="list-style-type: none"> • Closed: The bypass input 	Closed ^a

Silk Screen	Signal Description	Status Description	Initial Status
SWITCH STATUS_0V	Port for signal ground	circuit breaker is ON. • Open: The bypass input circuit breaker is OFF.	
SPD	Port for monitoring the input AC SPD	• Closed: The input AC SPD is normal. • Open: The input AC SPD fails.	Closed ^a
0V	Port for signal ground		
a: On the LCD, choose System Info > Settings > System Settings > Dry Contact Set > MUE05A DI type configure , and customize the initial status of Battery ground fault [BTG], D.G. connection [GEN], PDC output breaker [OUT], PDC maintenance breaker [MT], BP/SYSMT switch, and SPD/SYSOUT switch .			

3.3.4 Monitoring Interface Card

The monitoring interface card provides external ports as well as monitoring and control functions for the monitoring display unit (MDU). The monitoring interface card provides the ambient temperature and humidity sensor port, FE port, battery temperature monitoring port, and network management port. The MDU monitors the UPS, allows users to set parameters, delivers commands, reports system information, and displays key UPS information and parameters on the LCD.

NOTICE

- The FE port resembles the RS485 port. Therefore, follow the silk screens when you connect communications cables. If you mistake the RS485 port as the FE port during cable connection, the WebUI communication fails. If you mistake the FE port as the RS485 port during cable connection, RS485 communication fails.
- Dry contact signals take effect after you set them. Disable unused dry contact signals on the monitoring system.
- When multiple UPSs are connected in parallel, all dry contact signals to be used need to connect to each UPS.

Figure 3-7 Monitoring interface card

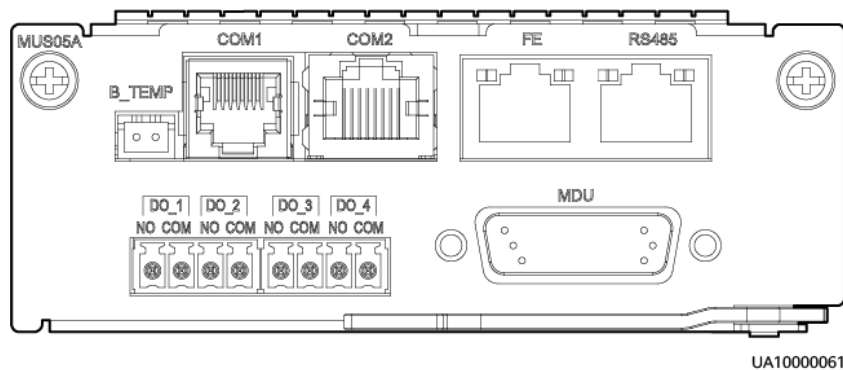

UA10000061

NOTE

DO_1 to DO_4 meet the maximum voltage and current requirements of 30 V DC/1 A or 60 V DC/0.5 A.

Table 3-8 Description of ports on the monitoring interface card

Port	Silk Screen	Description
DO_1	NO	<ul style="list-style-type: none"> • DO_1, DO_2, DO_3, and DO_4 indicate alarm outputs. The default values are Critical alarm, Minor alarm, Bypass mode, and Battery mode, respectively. • On the LCD, choose System Info > Settings > System Settings > Dry Contact Set. Set MUS05A DO_1, MUS05A DO_2, MUS05A DO_3, and MUS05A DO_4 to Disable, Critical alarm, Minor alarm, Bypass mode, Battery mode, Low batt.
	COM	
DO_2	NO	
	COM	
DO_3	NO	
	COM	
DO_4	NO	

Port	Silk Screen	Description
	COM	<p>volt., Batt. SOC below thres., Abnormal mains, Sys maint breaker enable, Sys outp breaker enable, Maint. breaker closed, No power supplied, Mains supplies power, ECO mode, Battery test, Batt. volt. below thres, Rack output overload, Battery temp. abnormal, and Battery EOD.</p> <ul style="list-style-type: none"> • Configure power segment settings based on backup time.
DB26	MDU	Supports FE, RS485, I2C, CAN, and other signals.
Battery temperature sensor port	B_TEMP	Connects to an indoor battery temperature sensor.
Southbound communications port 1	COM1	<ul style="list-style-type: none"> • Supported protocol: Modbus-RTU • Connects to an ambient temperature and humidity sensor over two wires.
Southbound communications port 2	COM2	<ul style="list-style-type: none"> • Supported protocol: Modbus-RTU • Connects to a southbound device.
Network port	FE	<ul style="list-style-type: none"> • Supported protocols: Modbus-TCP, HTTPS, and SNMP • Connects to the network port on a PC. • Network port for connecting to the web service and for SNMP networking
Northbound communications port	RS485	<ul style="list-style-type: none"> • Supported protocol: Modbus-RTU • Connects to a northbound network management device or third-party network management device over two wires.

 **NOTE**

- Signal cables must be double-insulated twisted cables. If the cable length is within 25–50 m, the cross-sectional area must be 0.5–1.5 mm².
- RS485 cables and FE cables must be shielded cables.

Figure 3-8 and Figure 3-9 are recommended wiring methods for DO ports.

Figure 3-8 Wiring method 1

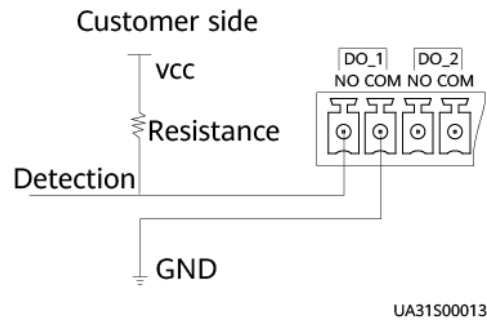

Figure 3-9 Wiring method 2

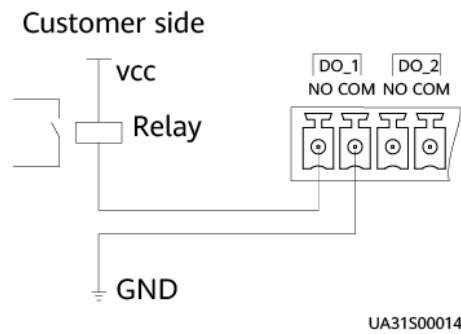

Figure 3-10 COM1 port pins

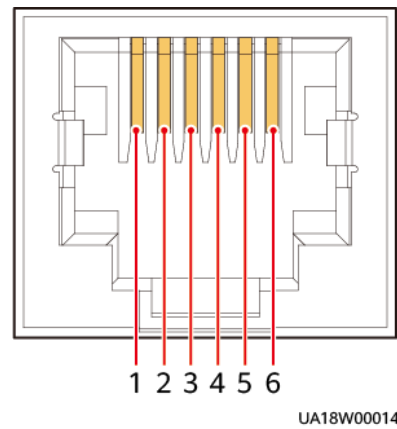

Table 3-9 Pin definitions for the COM1 port

Pin	Description
1	GND
2	-

Pin	Description
3	RS485-
4	RS485+
5	-
6	12V_PORT

Figure 3-11 COM2 port pins

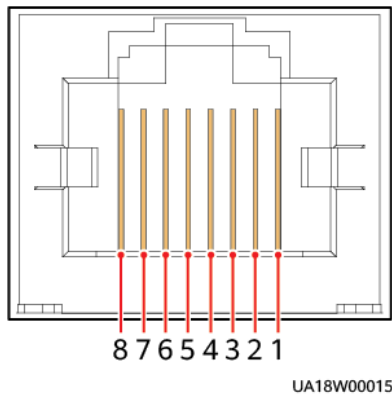

Table 3-10 Pin definitions for the COM2 port

Pin	Description
1	RS485+
2	RS485-
3	-
4	RS485+
5	RS485-
6	GND
7	CANH0
8	CANL0

Figure 3-12 RS485 port pins

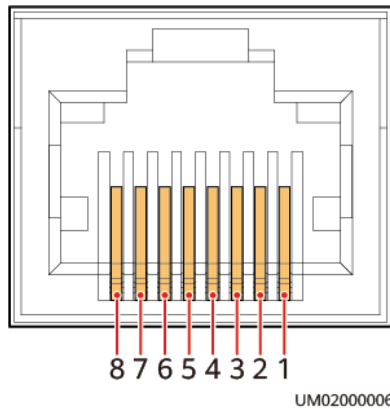

Table 3-11 Pin definitions for the RS485 port

Pin	Description
1	RS485_T+
2	RS485_T-
3	-
4	RS485_R+
5	RS485_R-
6	GND
7	-
8	-

NOTE

If cables are prepared onsite, follow the three methods below:

- Connect pin 1 and pin 2. Pin 1 connects to RS485+ and pin 2 connects to RS485-.
- Connect pin 4 and pin 5. Pin 4 connects to RS485+ and pin 5 connects to RS485-.
- Connect pins 1, 2, 4, and 5. Twist cables to pin 1 and pin 4 into one cable and then connect it to RS485+. Twist cables to pin 2 and pin 5 into one and then connect it to RS485-.

3.4 Intelligent Detection Card

In the integrated UPS solution, the intelligent detection card detects the temperatures of the copper bars, switches, and environments of the battery, bypass input, mains input, output, bypass input of the switch cabinet, mains input of the

switch cabinet, and output of the switch cabinet, and monitors the status of the mains input, bypass input, and output switches of the switch cabinet.

It is 1 U high and supports hot swap.

Figure 3-13 Intelligent detection card

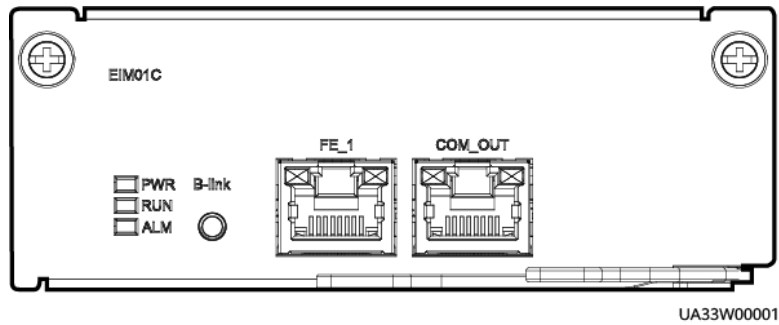

Table 3-12 Intelligent detection card function

Silk Screen	Description
FE_1	Reserved
COM_OUT	Reserved

Table 3-13 Indicator description

Indicator	Color	Status	Description
PWR	Green	Steady on	Indicates the CPU power status of the intelligent detection card. The indicator is steady on after the card is powered on and does not need to be controlled by the CPU.
		Off	Indicates that the intelligent detection card is powered off.
RUN	Green	Blinking at 0.5 Hz	The intelligent detection card is running properly.
		Blinking at 4 Hz	The communication is interrupted.
ALM	Red	Steady on	An alarm is generated.
		Off	No alarm is generated.

NOTE

- Signal cables must be double-insulated twisted cables. If the cable length is within 25–50 m, the cross-sectional area must be 0.5–1.5 mm².
- RS485 cables and FE cables must be shielded cables.

Figure 3-14 COM_OUT port pins

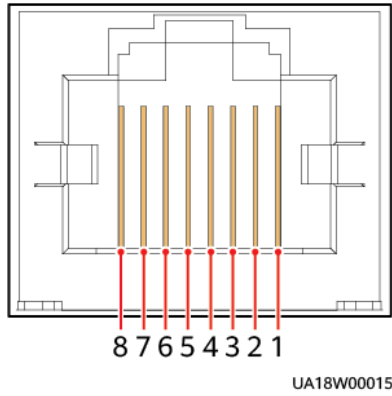

Table 3-14 Pin definitions for the COM_OUT port

Pin	Description
1	RS485+
2	RS485-
3	-
4	RS485+
5	RS485-
6	-
7	CANH
8	CANL

Figure 3-15 FE_1 port pins

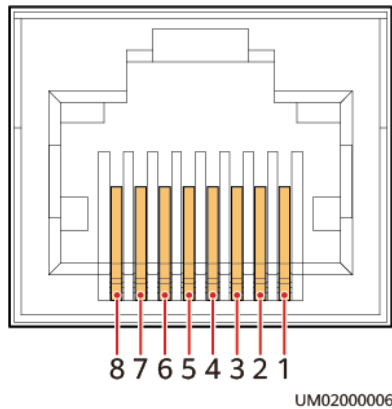

Table 3-15 Pin definitions for the FE_1 port

Pin	Description
1	FE4_TX+
2	FE4_TX-
3	FE4_RX+
4	-
5	-
6	FE4_RX-
7	-
8	-

3.5 Surge Protection Box

The surge protection box is used to improve the surge protection capability for the UPS. It applies to a three-phase + PE power system.

Figure 3-16 Surge protection box

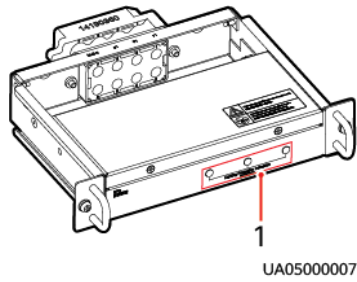

(1) Working status indicators

3.6 MDU

The MDU allows you to control UPS operations, view the running status and alarms, and set parameters.

Dimensions (H x W x D): 175 mm x 264 mm x 40 mm

Figure 3-17 Appearance

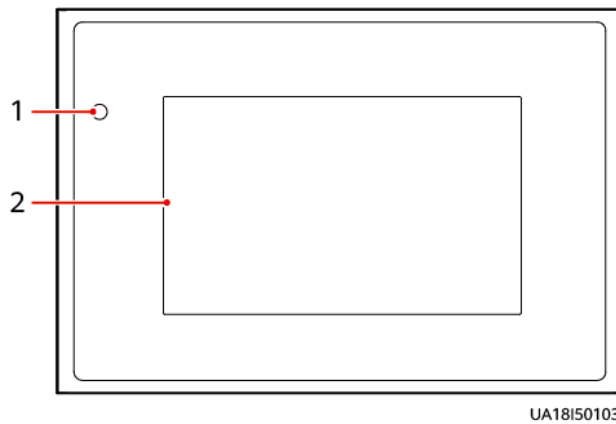

(1) Status indicator

(2) LCD touchscreen

Table 3-16 Indicator status

Status	Color	Meaning
On	Red	A critical alarm has been generated, and the buzzer sounds continuously.
	Yellow	A minor alarm has been generated, and the buzzer buzzes intermittently at 2 Hz.

Status	Color	Meaning
	Green	The UPS is running properly or a warning has been generated.
Off	-	The MDU is powered off.

NOTE

The indicator on the MDU panel is yellow when the bypass supplies power in non-ECO mode.

Figure 3-18 MDU ports

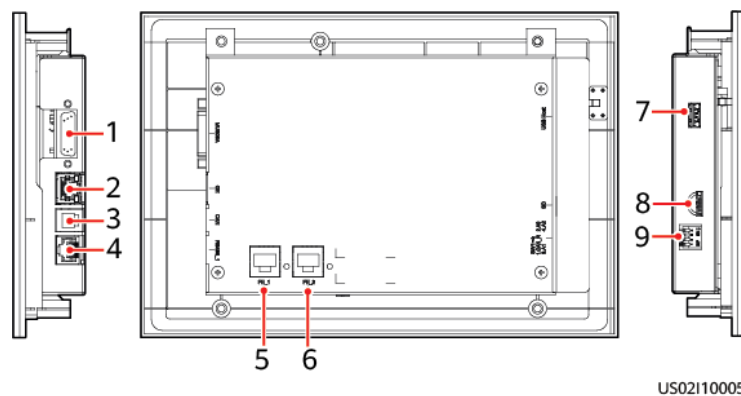

Table 3-17 MDU port description

No.	Port Name	Description
1	MUS05A (DB26)	Connects to the MDU and monitoring interface card.
2	GE	Network port
3	CAN	Reserved
4	RS485_1	Reserved
5	FE_1	Reserved
6	FE_2	Reserved

No.	Port Name	Description
7	USB Host	<ul style="list-style-type: none">• After installing the WiFi module, locally connect to the UPS over the Service Expert app. Obtain the initial startup password during deployment. View or obtain UPS running information during inspection. <p>NOTE The user must be a technical support engineer. To ensure security, remove the WiFi module immediately after use.</p> <ul style="list-style-type: none">• Insert a USB flash drive to import and export configuration files, export run logs, and upgrade software.
8	SD	Reserved
9	DIP switch	Implements specific functions by using the DIP switch and specific buttons; controls the CAN communication build-out resistor in a parallel system.

4 Optional Components

4.1 List of Optional Components

Optional Component	Model	Function
BCB box (only for lead-acid batteries)	<ul style="list-style-type: none">• PDU8000-0400DCV8-BXA001• PDU8000-0630DCV8-BXA001• PDU8000-0800DCV8-BXA001	Controls the connection between battery strings and the UPS, and supports overload protection, short circuit protection, and remote trip control.
Dry contact extended card	-	Provides extended monitoring ports: five relay output ports and five input ports.
Backfeed protection card	-	Detects mains and bypass backfeed and provides protection.
ECM extended subrack	-	Installed when the UPS is equipped with a backfeed protection card and dry contact extended card.
Ambient temperature and humidity (T/H) sensor	-	Monitors ambient temperature and humidity.
BSC cable	10 m/15 m/60 m	Transmits bus synchronization signals in a dual-bus system.
Parallel cable	5 m/10 m/15 m	Connects UPSs in parallel.
Top air-flow cabinet	-	Applies to the top airflow scenario.
Rear copper bar protection component	-	Protects copper bars at the rear of the cabinet.

Optional Component	Model	Function
Bottom cabling cabinet	-	Applies to the bottom cabling scenario.
Transfer copper bar for bottom cabling	-	
Top cabling component	-	Applies to the top cabling scenario.
Inductor cabinet	-	An inductor cabinet is required when the UPS is the three-phase three-wire model.

NOTE

The ECM extended subrack does not support onsite installation. If you require this optional component, inform the Company when you purchase the UPS so that it can install the subrack before delivery.

4.2 Dry Contact Extended Card

The dry contact extended card provides five groups of electric relay output ports for dry contact signals and five groups of signal input ports to implement various alarm and control functions as required.

A maximum of one dry contact extended card supported in the power monitoring subrack. The card is hot swappable.

Figure 4-1 Appearance

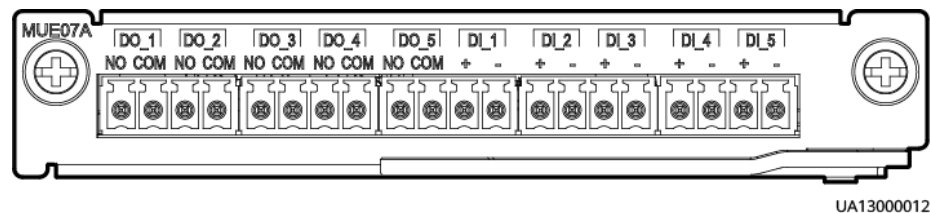

NOTICE

For dry contact outputs, the rated DC voltage and current are 24 V DC and 0.6 A and the maximum values are 30 V DC and 1.0 A. The rated AC voltage and current are 24 V AC and 0.6 A and the maximum values are 30 V AC and 1.0 A. During cable connection, ensure that the voltage and current do not exceed these maximum values.

Table 4-1 Port definitions for the dry contact extended card

Port		Silk Screen	Signal Description
Output	DO_1	NO	<ul style="list-style-type: none"> Indicates relay output signals. The dry contact is normally open by default. When the preset status occurs, the relay is closed. Users can set the dry contacts to normally open or closed based on actual requirements. On the LCD, choose System Info > Settings > System Settings > Dry Contact Set. Set MUE07A DO_1, MUE07A DO_2, MUE07A DO_3, MUE07A DO_4, and MUE07A DO_5 to Disable, Critical alarm, Minor alarm, Bypass mode, Battery mode, Low batt. volt., Batt. SOC below thres., Abnormal mains, Sys maint breaker enable, Sys outp breaker enable, Maint. breaker closed, No power supplied, Mains supplies power, ECO mode, Battery test, Batt. volt. below thres, Rack output overload, Battery temp. abnormal, and Battery EOD. MUE07A DO_1 is set to Low batt. volt. by default. Others are reserved by default. DOs transmit passive dry contact output signals. Users need to connect external power supply to DOs.
		COM	
	DO_2	NO	
		COM	
	DO_3	NO	
		COM	
	DO_4	NO	
		COM	
	DO_5	NO	
		COM	
Input	DI_1	+	<ul style="list-style-type: none"> All DIs are reserved. On the LCD, choose System Info > Settings > System Settings > Dry Contact Set and set MUE07A DI_1–MUE07A DI_5 to values such as Door alarm and Water alarm. The default value is None. DI ports detect input dry contact signals which are passive signals.
		-	
	DI_2	+	
		-	
	DI_3	+	
		-	
	DI_4	+	
		-	
	DI_5	+	
		-	

The following wiring methods are recommended for DO ports.

Figure 4-2 Wiring method 1

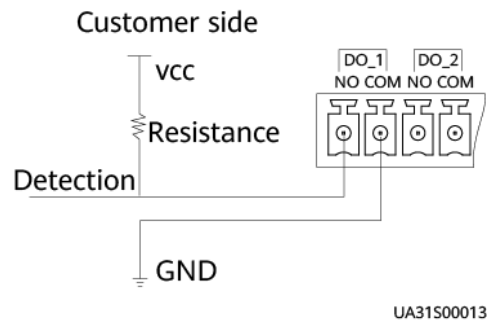
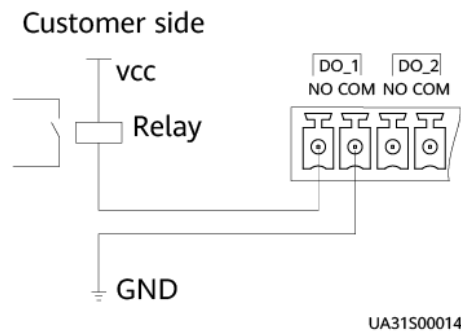

Figure 4-3 Wiring method 2



4.3 Backfeed Protection Card

When energy backfeed occurs, the backfeed protection card sends signals to trigger alarm signals or quickly disconnect the feedback loop. The card is hot swappable.

Figure 4-4 Appearance

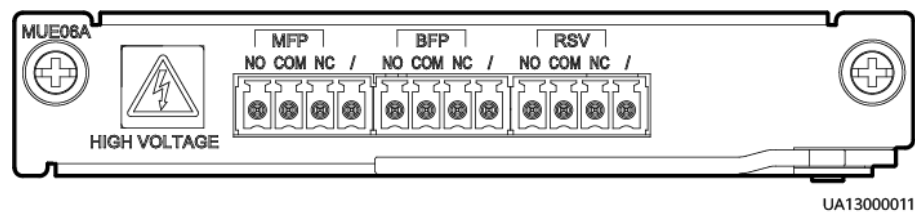

Figure 4-5 Ports on the backfeed protection card

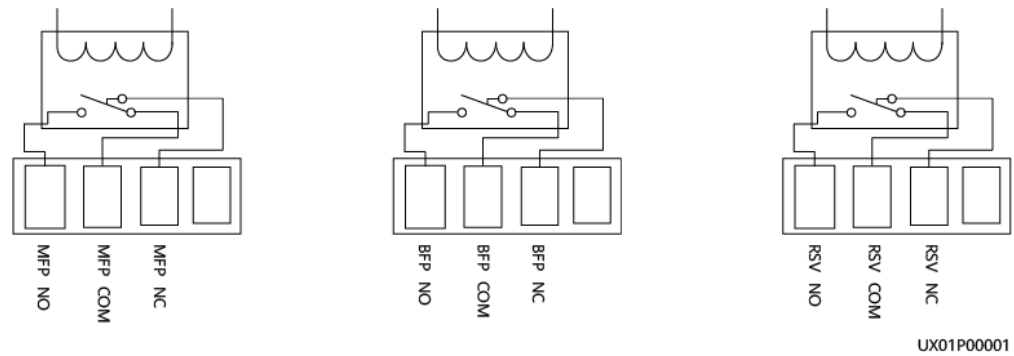

Table 4-2 Port description for the backfeed protection card

Port Position	Silk Screen	Signal Description
MFP (mains feedback protection)	MFP_NO	The MFP port is the signal port for the mains backfeed protection. NO and COM are normally open contacts. NC and COM are normally closed contacts. When a backfeed occurs, the normally open contacts are closed and the normally closed contacts are open.
	MFP_COM	
	MFP_NC	
BFP (bypass feedback protection)	BFP_NO	The BFP port is the signal port for the bypass backfeed protection. NO and COM are normally open contacts. NC and COM are normally closed contacts. When a backfeed occurs, the normally open contacts are closed and the normally closed contacts are open.
	BFP_COM	
	BFP_NC	
RSV (reserved)	RSV_NO	Reserved
	RSV_COM	
	RSV_NC	

4.4 BCB Box

The BCB box controls the connection between battery strings and the UPS, and supports overload protection, short circuit protection, and remote trip control.

Figure 4-6 Appearance

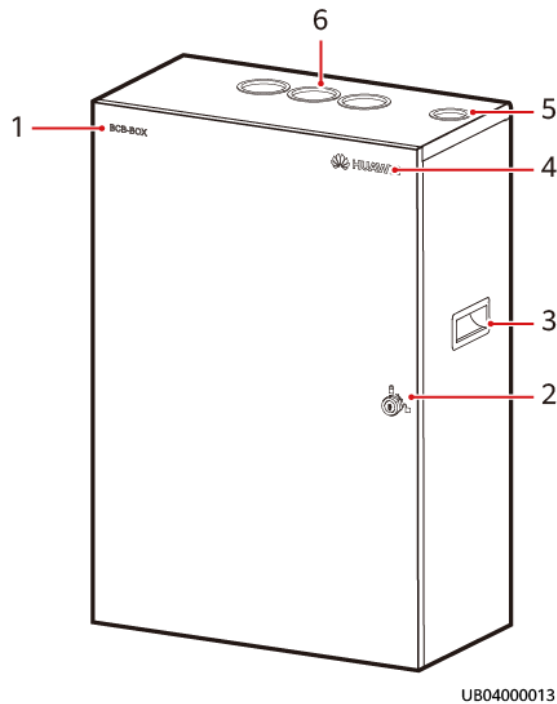

- (1) Silk screen (2) Door lock (3) Handle
- (4) Huawei logo (5) Signal cable outlet (6) Power cable outlets

Table 4-3 Specifications

Item	PDU8000-0400D CV8-BXA001	PDU8000-0630D CV8-BXA001	PDU8000-0800 DCV8-BXA001
Rated current (A)	400	630	800
Rated voltage (V DC)	750	750	750
Breaking capacity (kA)	16	20	36
IP rating	20	20	20

4.5 Ambient T/H Sensor

The ambient temperature and humidity (T/H) sensor monitors the ambient temperature and humidity in the equipment room to ensure that the equipment works properly.

The ambient T/H sensor can also be used as a battery temperature sensor. The monitoring module distinguishes these two types of sensors through their DIP switch settings.

Figure 4-7 Appearance

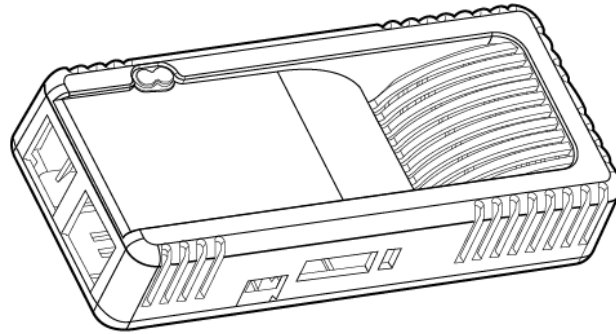

UA08000072

The RS485 communications port of the T/H sensor is an RJ11 (6P6C) port. If multiple T/H sensors need to be cascaded, connect the RJ11 port on each T/H sensor.

Figure 4-8 RJ11 port

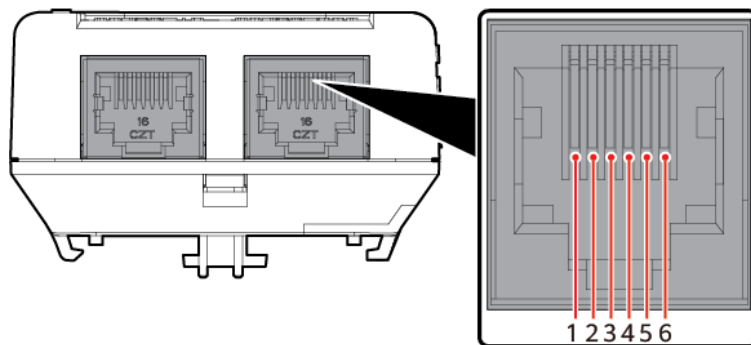

UA01000025

Table 4-4 Pins on the RJ11 port

Pin No.	Signal
1	GND
2	-
3	S_RS485B_R-
4	S_RS485B_R+
5	-

Pin No.	Signal
6	12V_OUT

4.6 Top Air-Flow Cabinet

Applies to the top airflow scenario.

Figure 4-9 Appearance

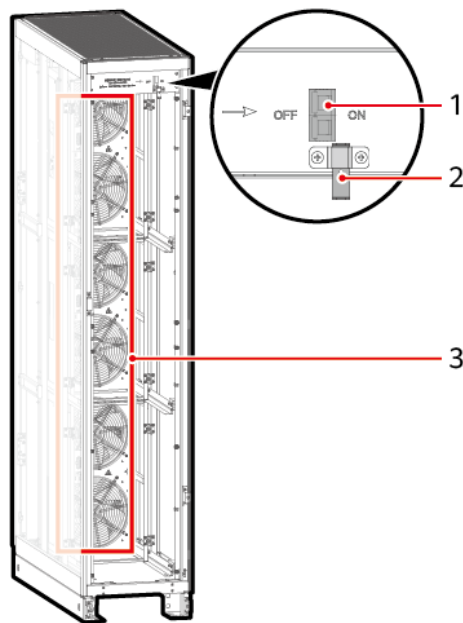

UF03W00004

(1) Fan power switch

(2) Cover stopper

(3) Fans

Table 4-5 Specifications

Item	Specifications
Dimensions (H x W x D)	2000 mm x 400 mm x 1000 mm
Weight	150 kg

4.7 Bottom Cabling Cabinet

Applies to the bottom cabling scenario.

Cabinet dimensions (H x W x D): 2000 mm x 400 mm x 1000 mm (excluding the top frame and copper bars)

For details about the appearance of the combination with the UPS, see the section about cabinet description.

Figure 4-10 Cabinet

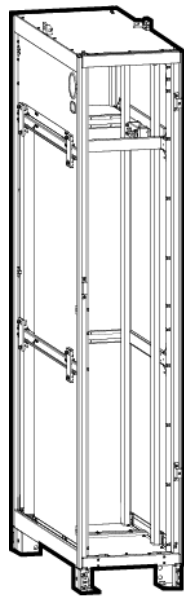

UF03H00223

4.8 Rear Copper Bar Protection Component

Protects copper bars at the rear of the cabinet.

Figure 4-11 Appearance

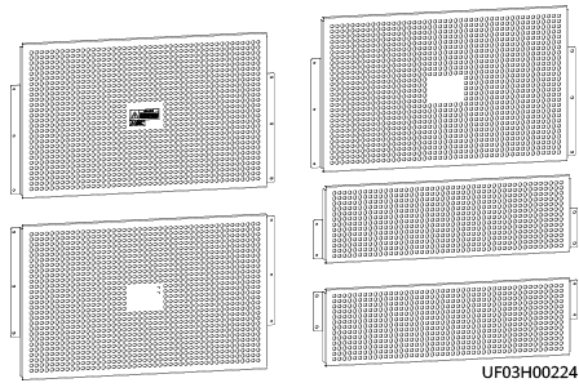

4.9 Top Cabling Component

Applies to the top cabling scenario.

Figure 4-12 Copper bar assembly (1200 kVA)

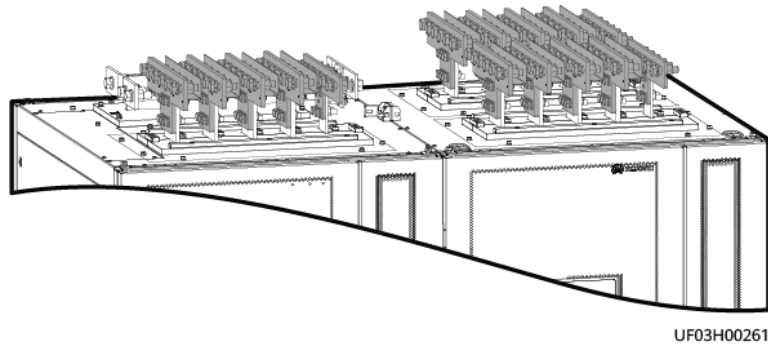

Figure 4-13 Top frame (1200 kVA)

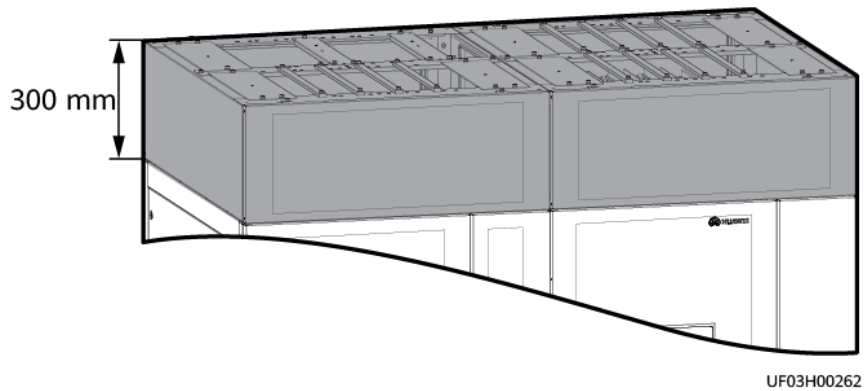

Figure 4-14 Copper bar assembly (1600 kVA)

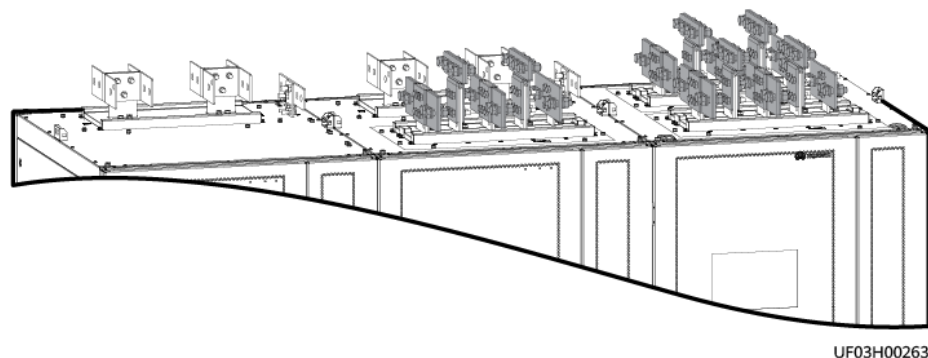
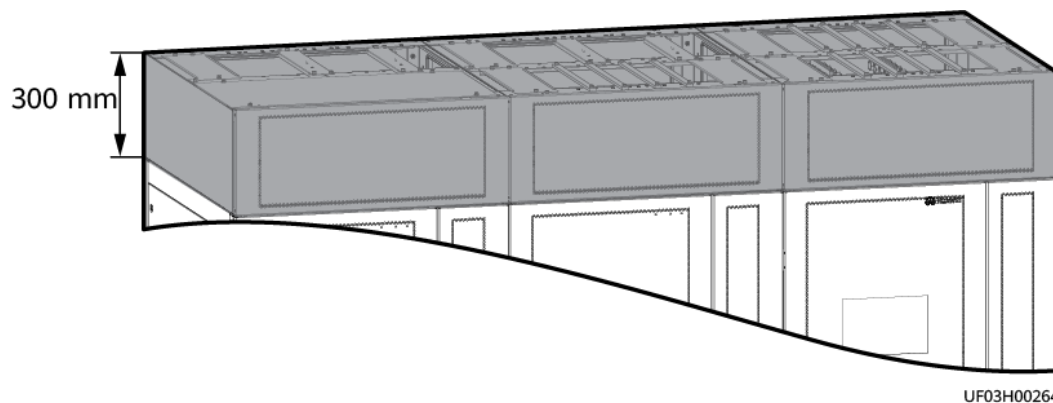

Figure 4-15 Top frame (1600 kVA)



4.10 Inductor Cabinet

It is used for the three-phase three-wire model.

Dimensions (H x W x D): 2000 mm x 600 mm x 1000 mm

Weight: 1100 kg

Figure 4-16 Interior

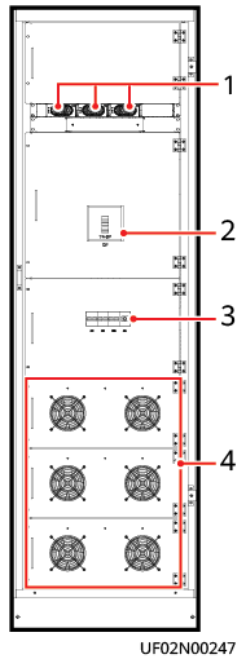

(1) Rectifiers

(2) Main switch QF of the inductor cabinet

(3) Inductor cabinet fan power switches
QS1-4

(4) Fans

4.10.1 Rectifier

A rectifier converts AC input power into stable DC power for the fan in the inductor cabinet.

Figure 4-17 Appearance

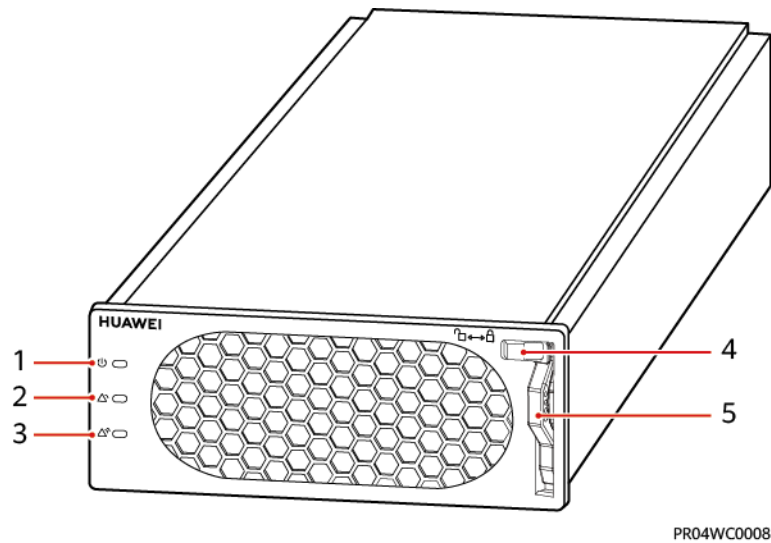

- (1) Power indicator (2) Alarm indicator (3) Fault indicator
 (4) Locking latch (5) Handle

Table 4-6 Indicator description

Indicator	Color	Status	Description
Power indicator	Green	Steady on	The rectifier has an AC input.
		Off	There is no AC input.
		Blinking at 0.5 Hz	The rectifier is faulty.
		Blinking at 4 Hz	Querying is in progress.
Alarm indicator	Yellow	Off	The rectifier has no protection alarm.
		Steady on	<ul style="list-style-type: none"> The rectifier has generated a warning due to ambient overtemperature. The rectifier has generated a shutdown alarm for protection due to ambient overtemperature or undertemperature.

Indicator	Color	Status	Description
			AC input overvoltage or undervoltage protection has been triggered.
			The rectifier is hibernating.
		Blinking at 0.5 Hz	The communication between the rectifier and the external equipment is interrupted. (When rectifiers are used in an inductor cabinet, they do not need to communicate with external devices. It is normal that the alarm indicator blinks at 0.5 Hz.)
Fault indicator	Red	Off	The rectifier is normal.
		Steady on	The rectifier locks out due to output overvoltage.
			The rectifier has no output due to an internal fault.

Table 4-7 Specifications

Item	Specifications
Dimensions (H x W x D)	40.8 mm x 95.5 mm x 208 mm
Weight	≤ 1.5 kg

5 Technical Specifications

5.1 Physical Specifications

Table 5-1 Physical specifications

Item	1200 kVA	1600 kVA
Cabling mode	Battery cables are routed in and out from the top, and input and output cables are connected using the busway (without optional components). Top cabling (with a top cabling component) Bottom cabling (with a bottom cabling cabinet)	
IP rating	IP20	
Communication	Supports dry contacts, RS485 ports, and FE ports. Supports SNMP and Modbus.	

Item	1200 kVA	1600 kVA
Dimensions (H x W x D)	2200 mm x 1600 mm x 1000 mm (without optional components) 2300 mm x 1600 mm x 1000 mm (with a top cabling component) 2200 mm x 2400 mm x 1000 mm (with a bottom cabling cabinet) 2200 mm x 2000 mm x 1000 mm (with a top air-flow cabinet) 2300 mm x 2000 mm x 1000 mm (with a top cabling component + top air-flow cabinet) 2200 mm x 2200 mm x 1000 mm (with an inductor cabinet) 2300 mm x 2200 mm x 1000 mm (with an inductor cabinet + top cabling component) 2200 mm x 3000 mm x 1000 mm (with an inductor cabinet + bottom cabling cabinet) 2200 mm x 2600 mm x 1000 mm (with an inductor cabinet + top air-flow cabinet) 2300 mm x 2600 mm x 1000 mm (with an inductor cabinet + top cabling component + top air-flow cabinet)	2200 mm x 2400 mm x 1000 mm (without optional components) 2300 mm x 2400 mm x 1000 mm (with a top cabling component) 2200 mm x 3200 mm x 1000 mm (with a bottom cabling cabinet) 2200 mm x 3200 mm x 1000 mm (with a top air-flow cabinet) 2300 mm x 3200 mm x 1000 mm (with a top cabling component + top air-flow cabinet) 2200 mm x 3000 mm x 1000 mm (with an inductor cabinet) 2300 mm x 3000 mm x 1000 mm (with an inductor cabinet + top cabling component) 2200 mm x 3800 mm x 1000 mm (with an inductor cabinet + bottom cabling cabinet) 2200 mm x 3800 mm x 1000 mm (with an inductor cabinet + top air-flow cabinet) 2300 mm x 3800 mm x 1000 mm (with an inductor cabinet + top cabling component + top air-flow cabinet)

Item	1200 kVA	1600 kVA
Weight	< 1600 kg (without optional components) < 1695 kg (with a top cabling component) < 2005 kg (with a bottom cabling cabinet) < 1750 kg (with a top air-flow cabinet) < 1845 kg (with a top cabling component + top air-flow cabinet) < 2700 kg (with an inductor cabinet) < 2795 kg (with an inductor cabinet + top cabling component) < 3105 kg (with an inductor cabinet + bottom cabling cabinet) < 2850 kg (with an inductor cabinet + top air-flow cabinet) < 2945 kg (with an inductor cabinet + top cabling component + top air-flow cabinet)	< 2300 kg (without optional components) < 2410 kg (with a top cabling component) < 2807 kg (with a bottom cabling cabinet) < 2600 kg (with a top air-flow cabinet) < 2710 kg (with a top cabling component + top air-flow cabinet) < 3400 kg (with an inductor cabinet) < 3510 kg (with an inductor cabinet + top cabling component) < 3907 kg (with an inductor cabinet + bottom cabling cabinet) < 3700 kg (with an inductor cabinet + top air-flow cabinet) < 3810 kg (with an inductor cabinet + top cabling component + top air-flow cabinet)

5.2 Environmental Specifications

Table 5-2 Environmental specifications

Item	Specifications
Operating temperature	0–55°C Temperature derating coefficient: not derated at 0°C–40°C, derated to 0.9 at 41°C–45°C, derated to 0.8 at 46°C–50°C, and derated to 0.7 at 51°C–55°C
Storage temperature	–40°C to +70°C
Humidity	0%–95% RH (non-condensing)
Altitude	0–1000 m When the altitude is greater than 1000 m, the power is derated as described in IEC 62040-3. The upper limit of the altitude is 4000 m.

5.3 Safety Compliance and ECM Specifications

Table 5-3 Safety compliance

Safety Certification	Standard
CE	EN 62040-1:2013
CB	IEC 62040-1:2013
TUV	EN 62040-1:2013
CQC	CQC 3108-2011
CCC	GB 7260.1-2008
TLC	YD/T 2165-2017
RCM	IEC 62040-2

Table 5-4 EMC

EMC Test Item	Standard
Conducted emission	EN/IEC 62040-2
Radiated emission	EN/IEC 62040-2
Low-frequency signal interference	IEC 61000-2-2
ESD immunity	IEC 61000-4-2
Conducted susceptibility	EN/IEC 62040-2 EN/IEC 61000-4-6
Radiated susceptibility	EN/IEC 62040-2 EN/IEC 61000-4-3
Electrical fast transient	EN/IEC 62040-2 IEC 61000-4-4
Surge	EN/IEC 62040-2 IEC 61000-4-5
Impact current (lightning protection)	5 kA (common mode), criterion B
Voltage dips and short interruptions (220 V AC)	IEC 61000-4-11

EMC Test Item	Standard
Power frequency magnetic field	IEC 61000-4-8

5.4 Mains Input Electrical Specifications

Table 5-5 Mains input electrical specifications

Item	Specifications
Power system	Three-phase four-wire + PE/Three-phase three-wire + PE
Rated voltage	380 V AC/400 V AC/415 V AC (line voltage)
Voltage range	0–30°C: not derated at 323–485 V AC, derated from 100% load to 45% load at 323–191 V AC, and derated from 45% load to 35% load at 191–138 V AC 30–40°C: not derated at 342–485 V AC, derated from 100% load to 45% load at 342–191 V AC, and derated from 45% load to 35% load at 191–138 V AC
Rated frequency	50 Hz/60 Hz
Frequency range	40–70 Hz
Power factor	<ul style="list-style-type: none"> • > 0.99 (100% load) • > 0.98 (50% load) • > 0.94 (30% load)
Harmonic current	<ul style="list-style-type: none"> • THDi < 9% (30% linear load), THDi < 6% (50% linear load), THDi < 3% (100% linear load) • THDi < 11% (30% non-linear load), THDi < 8% (50% non-linear load), THDi < 5% (100% non-linear load) Remarks: <ol style="list-style-type: none"> 1. The preceding specifications are met when the mains input and bypass input share a power source. 2. The input THDu is less than 2%.

5.5 Bypass Input Electrical Specifications

Table 5-6 Bypass input electrical specifications

Item	Specifications
Power system	Three-phase four-wire + PE/Three-phase three-wire + PE
Rated voltage	380 V AC/400 V AC/415 V AC (line voltage)
Rated frequency	50 Hz/60 Hz
Frequency range	50 Hz/60 Hz \pm 6 Hz (adjustable with a tolerance of 0.5–6 Hz, \pm 2 Hz by default)
Input mode	The mains input and bypass input share a power source (by default) or use different power sources.

5.6 Battery Electrical Specifications

NOTICE

The UPS supports the SmartLi. For details about the parameters, see the *SmartLi User Manual*.

Table 5-7 Battery electrical specifications

Item	Specifications
------	----------------

Item	Specifications
Battery voltage (lead-acid battery)	360–600 V DC <ul style="list-style-type: none"> • 12 V batteries (30–50 batteries optional, 0 by default) <ul style="list-style-type: none"> – 40–50 batteries: not derated – 38–39 batteries: derated to 90% – 34–37 batteries: derated to 80% – 30–33 batteries: derated to 70% • 2 V batteries (180–300 batteries optional, 0 by default) <ul style="list-style-type: none"> – 240–300 batteries: not derated – 228–239 batteries: derated to 90% – 204–227 batteries: derated to 80% – 180–203 batteries: derated to 70% <p>NOTE The number of batteries is 0 by default and needs to be set based on site requirements. Batteries have no neutral wire, and an odd number of batteries are supported.</p>
Battery cold start	If a mains outage occurs, batteries can start the UPS to supply power to loads.
Charger output power	Under rated conditions, the maximum charge power is 15% of module power, and the charge current is limited to 30 A.
Battery string sharing	Lead-acid battery: Battery string sharing is supported in a parallel system. No battery is shared by default. SmartLi 2.0: Battery string sharing is supported. When multiple UPSs are connected in parallel, the lithium battery cabinet can be expanded for half a cabinet. No battery is shared by default. SmartLi 3.0: not supported
Charging voltage (lead-acid battery)	<ul style="list-style-type: none"> • Default equalized charging voltage: 2.35 V/cell • Default float charging voltage: 2.25 V/cell
Battery type	<ul style="list-style-type: none"> • VRLA • Adapts to SmartLi 2.0 and SmartLi 3.0 (SmartLi 3.0 supports only the three-phase four-wire 380 V AC/400 V AC/415 V AC voltage system).

5.7 Output Electrical Specifications

Table 5-8 Output electrical specifications

Item	1200 kVA	1600 kVA
Power system	Three-phase four-wire + PE/Three-phase three-wire + PE	
Voltage	380 V AC/400 V AC/415 V AC (line voltage)	
Frequency	<ul style="list-style-type: none"> In normal mode, the frequency is synchronous with the bypass input frequency. In battery mode, the frequency is 50 Hz/60 Hz with a tolerance of $\pm 0.05\%$. 	
Voltage distortion	<ul style="list-style-type: none"> Linear load THD < 1% (50–100% load balancing) Non-linear load THD < 3% (50–100% load balancing) 	
Power factor	1	
Transfer time (normal)	<ul style="list-style-type: none"> Double conversion mode: uninterrupted transfer 0 ms; interrupted transfer ≤ 5 ms S-ECO mode: 0 ms (supported only by the three-phase four-wire model) 	
Output voltage imbalance	Voltage imbalance: $\pm 1\%$ Phase imbalance: $120 \pm 1^\circ$	

Item	1200 kVA	1600 kVA
Inverter overload capability	<p>Inverter overload capability for front-to-back airflow:</p> <ul style="list-style-type: none"> • 105% < load ≤ 110%: transfers to bypass mode after 60 min or longer (ambient temperature ≤ 30°C) • 100% < load ≤ 110%: transfers to bypass mode after 60 min or longer (ambient temperature > 30°C) • 110% < load ≤ 125%: transfers to bypass mode after 10 min or longer • 125% < load ≤ 150%: transfers to bypass mode after 1 min or longer • Load > 150%: transfers to bypass mode after 200 ms or more; withstands at least 50 shocks <p>Inverter overload capability for top airflow:</p> <ul style="list-style-type: none"> • 100% < load ≤ 110%: transfers to bypass mode after 60 min or longer • 110% < load ≤ 125%: transfers to bypass mode after 10 min or longer (ambient temperature ≤ 30°C) • 110% < load ≤ 125%: transfers to bypass mode after 1 min or longer (ambient temperature > 30°C) • 125% < load ≤ 150%: transfers to bypass mode after 1 min or longer (ambient temperature ≤ 30°C) • 125% < load ≤ 150%: transfers to bypass mode after 20 seconds or more (ambient temperature > 30°C) • Load > 150%: transfers to bypass mode after 200 ms or more; withstands at least 50 shocks <p>Continuous overload interval: The preceding overload time is allowed again only 10 min after the system exits the overload state.</p>	
Inverter output short-circuit capability	If the initial load rate is less than 40%, the inverter output short-circuit can tolerate twice the rated current for 300 ms.	

Item	1200 kVA	1600 kVA
Bypass overload capability	<ul style="list-style-type: none"> 30°C: runs continuously at 135% load; generates only alarms and depends on overtemperature protection at 135–150% load 40°C: runs continuously at 125% load; generates only alarms and depends on overtemperature protection at 125–150% load At 40°C, if the load of the bypass single-phase or three-phase is 150%–200%, the bypass will be shut down in 5 min, and the hardware depends on overtemperature protection. If the load of the bypass single-phase or three-phase is greater than 200%, the bypass will be shut down in 1 min, and the hardware depends on overtemperature protection. Load > 1000%: runs for 100 ms 	<ul style="list-style-type: none"> 30°C: runs continuously at 110% load; runs for 10 min and then depends on overtemperature protection at 110%–125% load 40°C: runs continuously at 100% load; generates only alarms and depends on overtemperature protection at 100–125% load 40°C: generates only alarms and depends on overtemperature protection at 125%–1000% load Load > 1000%: runs for 100 ms

5.8 System Electrical Specifications

Table 5-9 System electrical specifications

Item	Specifications
Parallel system reliability	Redundant parallel signals
ECO in a parallel system	Supported
Number of parallel UPSs	<p>1200 kVA: A maximum of four UPSs can be connected in parallel. (For details about a parallel system where three-phase three-wire input and output cables are connected using a busway, contact marketing engineers.)</p> <p>1600 kVA: A maximum of two UPSs can be connected in parallel. (For details about a parallel system where three-phase three-wire input and output cables are connected using a busway, contact marketing engineers.)</p>

Item	Specifications
Power distribution system	TN-C, TN-S, TN-C-S, TT NOTE The three-phase three-wire corner-grounded delta power system is not supported.

A Lifting Trolley

Function

A lifting trolley is used as an auxiliary tool for replacing a power module or bypass module.

It is recommended that a lifting trolley be configured for each site to facilitate the maintenance of power modules and bypass modules. You can decide whether to choose it based on site requirements.

Appearance

Figure A-1 Lifting trolley



UF01H00041

- | | | |
|---------------------|----------------|---------------------|
| (1) Tabletop | (2) Handle | (3) Lowering switch |
| (4) Elevating pedal | (5) Foot brake | |

Specifications

Item	Specifications
Weight	115 kg
Load-bearing capacity	350 kg
Minimum height	360 mm
Maximum height	1580 mm
Tabletop dimensions (length x width)	900 mm x 700 mm

Usage

 **CAUTION**

- Overloading is prohibited.
 - Keep hands or feet away from the coverage area of the tabletop.
 - When placing a module, brake the lifting trolley to prevent it from moving.
 - Keep the lifting trolley properly for future maintenance.
-

Step 1 Release the brake of the lifting trolley and push the trolley to the required position.

Step 2 Brake the lifting trolley to stop it and check that it will not move.

Step 3 Repeatedly step on the elevating pedal to raise the tabletop to a proper height.

Step 4 Lift the lowering switch to slowly lower the tabletop to the required height.

----End

B Acronyms and Abbreviations

A	
AWG	American wire gauge
B	
BSC	bus synchronization controller
BCB-BOX	battery circuit breaker box
BBB-BOX	battery bus bar box
C	
CE	Conformite Europeenne
E	
ECO	economic control operation
EPO	emergency power off
ECM	energy control module
EOD	end of discharge
I	
IEC	International Electrotechnical Commission
L	
LCD	liquid crystal display
M	
MDU	monitoring display unit
P	
PE	protective earthing

PDU	power distribution unit
R	
RS485	Recommended Standard 485
S	
SOC	state of charge
STS	static transfer switch
SNMP	Simple Network Management Protocol
S-ECO	super economy control operation
T	
THDi	total distortion of the input current waveform
THDv	total harmonic distortion of output voltage
U	
UPS	uninterruptible power system
USB	Universal Serial Bus
V	
VRLA	valve-regulated lead acid battery
VFI	voltage frequency independent
VFD	voltage frequency dependent
VI	voltage independent