

Huawei AI Data Center Reference Design



Reliable



Agile



Sustainable

Contents

Preface	01
----------------	-----------

1. Prefabricated Solution	02
----------------------------------	-----------

Solution Overview	02
Module Overview	03
Reference Design (RD) 01-14	04

2 Steel Structure Solution	32
-----------------------------------	-----------

Solution Overview	32
Module Overview	33
Reference Design (RD) 15-21	34

3 Product Datasheet	47
----------------------------	-----------

Outdoor PowerPod	47
UPS	50
SmartLi	53
TMU	55
Fanwall	57

Preface

This manual systematically presents Huawei's data center facility solutions for AI intelligent computing scenarios. We propose two major reference design paradigms tailored to different scenario needs.

Prefabricated modular solutions, with the core system using fully prefabricated modular products, factory pre-integration, and Lego-style on-site installation, enable rapid delivery, compressing the data center construction cycle from 18 months to 6 months.

Steel structure solutions, where core components can be prefabricated in the factory and then transported to the construction site for assembly, reduce on-site construction workload, improve construction efficiency, and shorten the construction cycle.

In the above two construction forms, each solution is subdivided into three major sub-scenes: 50 kW/rack, 70 kW/rack, and 132 kW/rack, to meet the construction needs of multi-scenario intelligent computing centers.

This manual is both a phase summary of Huawei's exploration of intelligent computing center construction and a roadmap to the next-generation data center. We look forward to exploring with global customers and partners, unleashing more powerful computing power from every watt of electricity, and jointly building a solid foundation for the intelligent world.

Solution Overview

IT rack power: 50 kW/rack, 70 kW/rack, 132 kW/rack
 Capacity coverage: 1.74 MW-7.15 MW

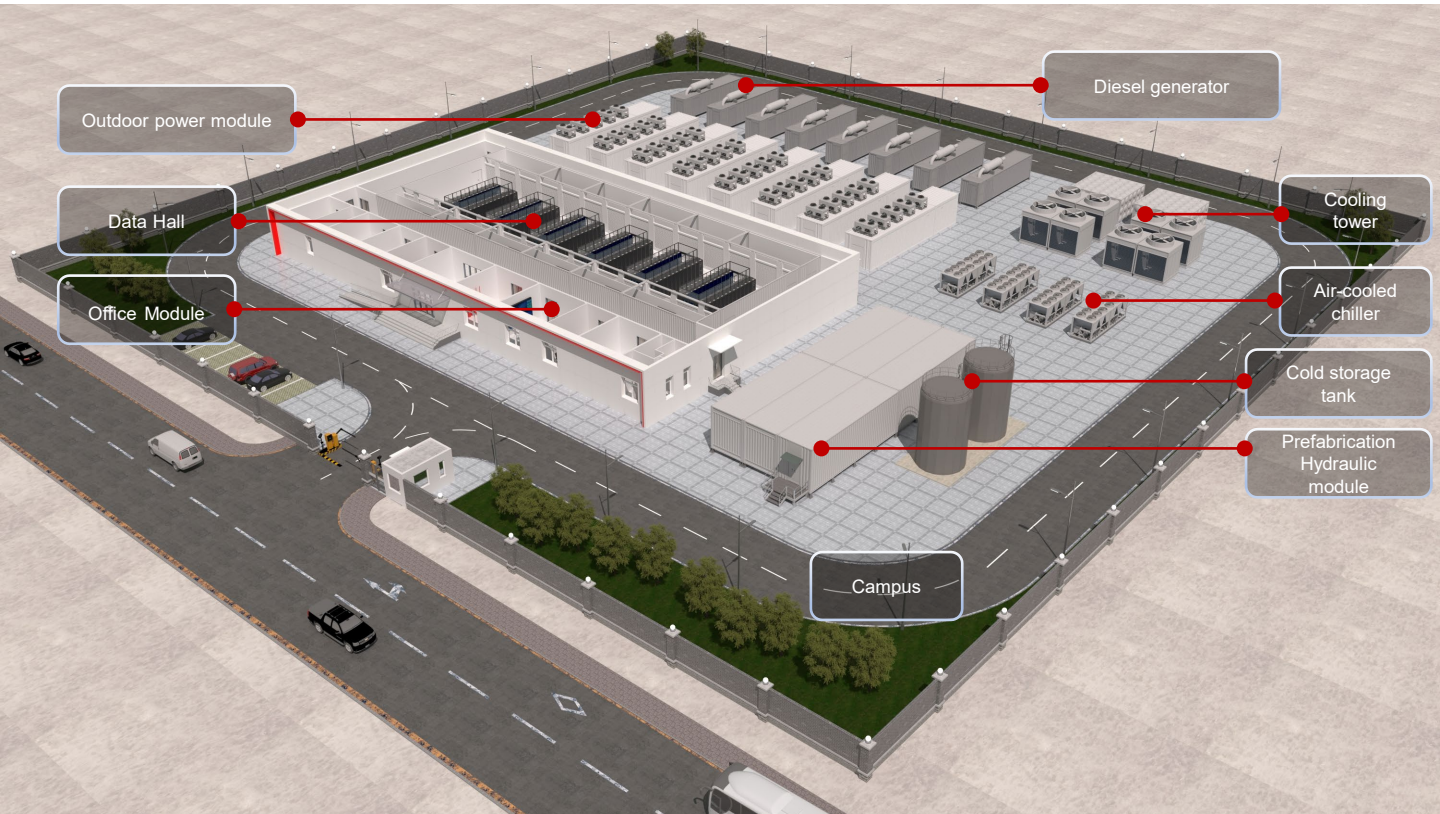

CFD

Circuit simulation

Cost evaluation

Structural Analysis

PUE Calculation

PIP Template

Features and Values

- Integrated Design** End-to-end design for power system, cooling system, campus layout, office areas, and auxiliary systems
- Modular Design** Data Hall, office modules, power modules, and hydraulic modules support rapid construction
- High Reliability** Distributed deployment of power and cooling system, single-fault isolation
- High Feasibility*** Leading regional cost baseline, PIP ≤ 9 Months

*Remarks: Based on Huawei's design and end-to-end ecological solutions

Module Overview

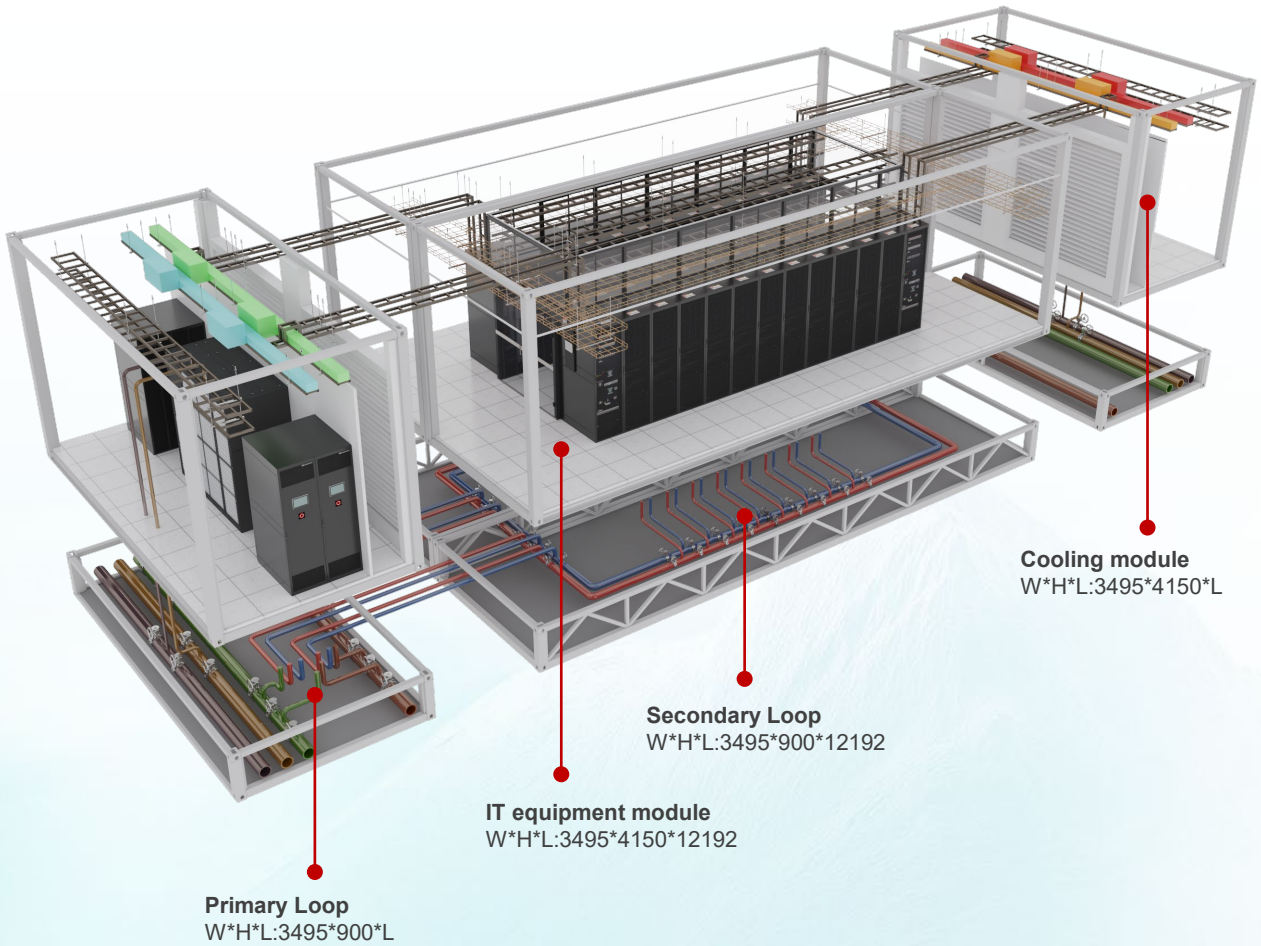

Module Design

IT Device module	IT rack, network rack, storage rack, PDC, power distribution ladder, cable tray, and integrated cabling
Cooling module	TMU thermal management unit, water-cooled fan wall, busbar, and power distribution ladder
Primary loop	Liquid cooling primary pipes, fan wall chilled water pipe, valves, instruments, and water leakage detection
Secondary loop	Liquid cooling secondary pipes, valves, instruments, and water leakage detection

Remarks:

1. Pipes can be deployed from top or bottom.
2. rack power distribution supports busbars or PDCs.

Design Overview

IT Load - 1744 kW

2 modules | 872 kW/module | 50 kW/Rack







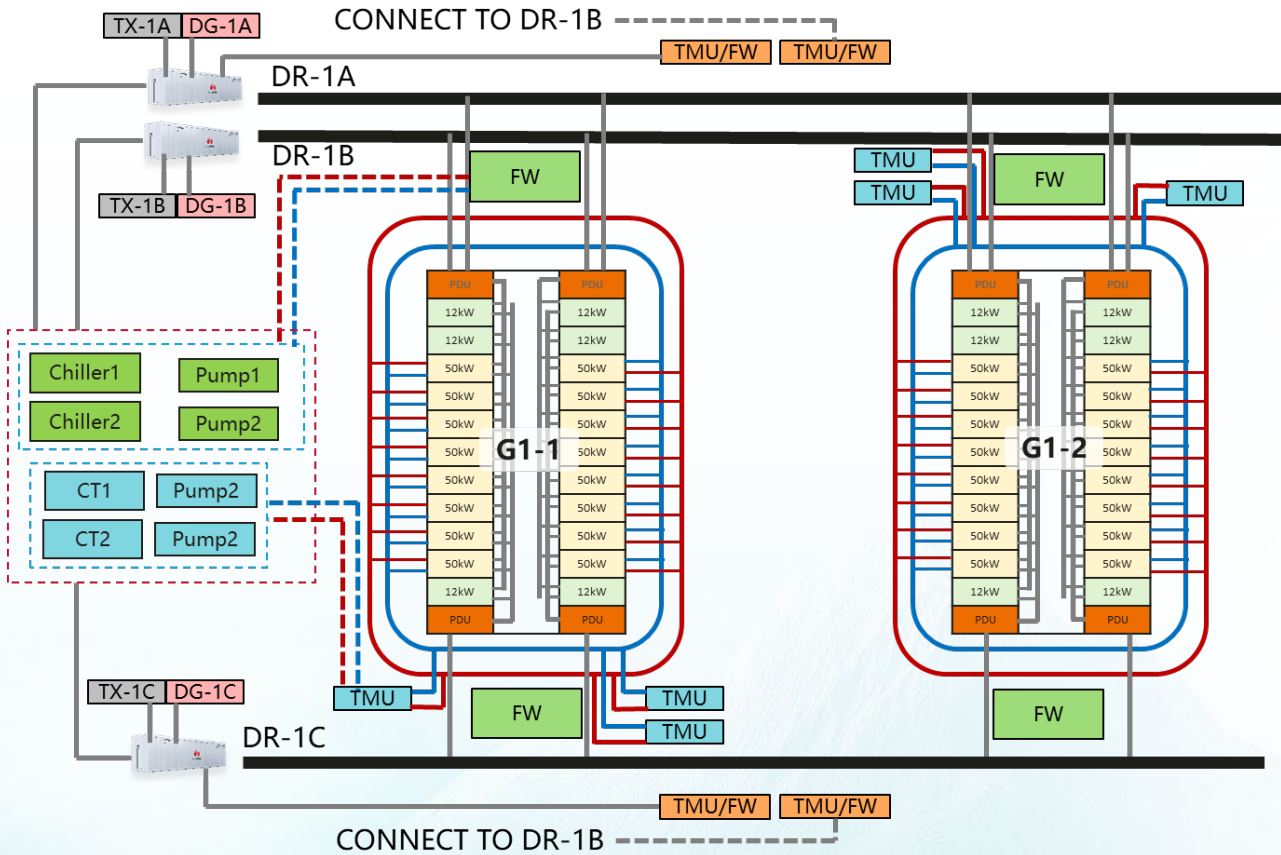

Overall Indicators

Total land area	7758 m2
DC Building area	974 m2
Total IT power	1744 kW
IT liquid cooling rack	50 kW/rack, 16 racks/module, 32 racks in total
Network rack	12 kW/rack, 6 racks/module, 12 racks in total
Design grade	Tier III
IT/Cooling power backup	10 min
Reference PUE	1.13

Block diagram



	Outdoor PowerPOD		Chilled Water Fan Wall		Thermal Management Unit
	Power Distribution Unit		Liquid supply		Liquid Return

Power system

Architecture*	3DR
Power module	1.8MW*3
Transformer	2000 kVA*3
Diesel generator	2000 kW DCC*3
PDU	(630 A x 2) x 4 units/module

Cooling system

Air-to-liquid ratio	3:7 (1:9-3:7)
Fan wall	210 kW/set, 4 + 1
TMU	360 kW, (2 + 1) * 2
Cooling tower	149 m ³ /h, 1 + 1
Air-cooled chiller	750 kW, 1 + 1

* Note: Power distribution architecture supports 2N, DR, and BR.

Design Overview

IT Load - 2616 kW

3 modules | 872 kW/module | 50 kW/Rack



Overall Indicators

Total land area	7758 m2
DC Building area	1176 m2
Total IT power	2616 kW
IT liquid cooling rack	50 kW/rack, 16 racks/module, 48 racks in total
Network rack	12 kW/rack, 6 racks/module, 18 racks in total
Design grade	Tier III
IT/Cooling power backup	10 min
Reference PUE	1.13

Block diagram

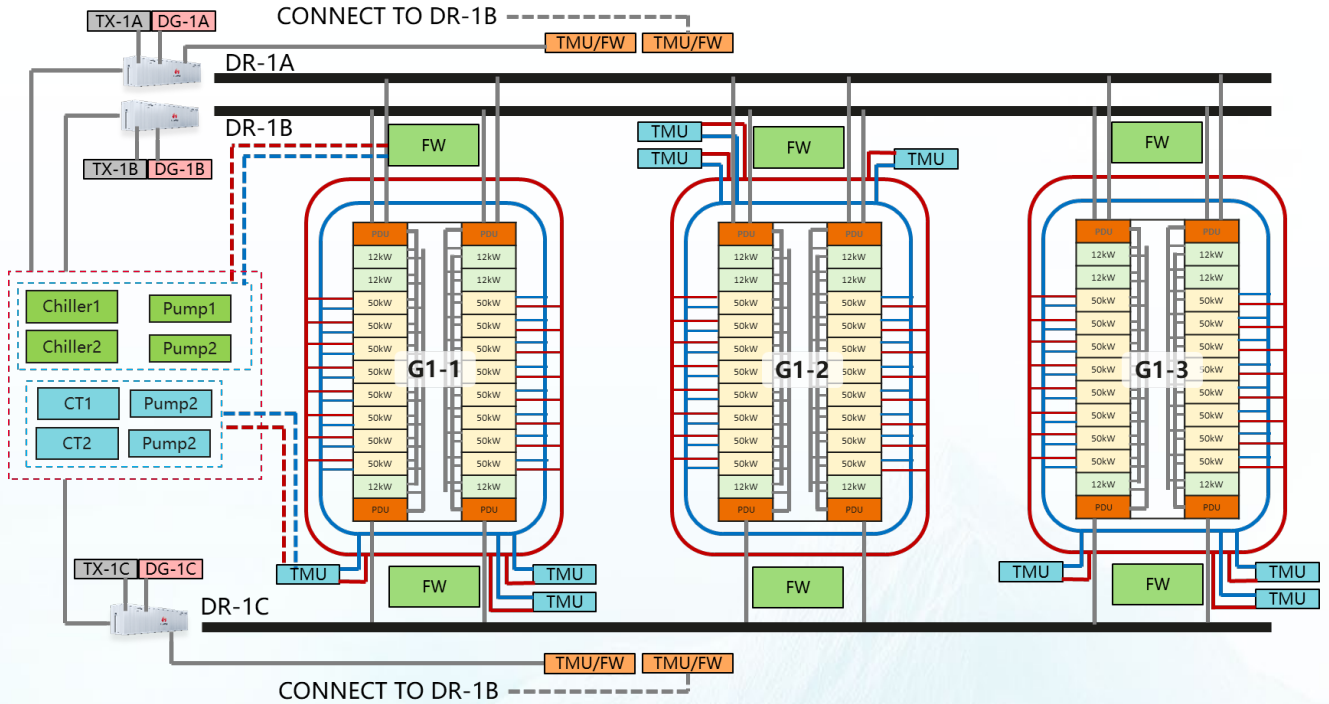

Outdoor PowerPOD



FW Chilled Water Fan Wall



TMU Thermal Management Unit



PDU Power Distribution Unit



Liquid supply



Liquid Return

Power system

Architecture*	3DR
Power module	2.4MW*3
Transformer	2500 kVA*3
Diesel generator	2200 kW DCC*3
PDU	(630 A x 2) x 4 units/module

Cooling system

Air-to-liquid ratio	3:7 (1:9-3:7)
Fan wall	210 kW/set, 6 + 2
TMU	360 kW, (2 + 1) * 3
Cooling tower	222 m ³ /h, 1 + 1
Air-cooled chiller	1075 kW, 1 + 1

* Note: Power distribution architecture supports 2N, DR, and BR.

Design Overview

IT Load - 3488 kW

4 modules | 872 kW/module | 50 kW/Rack



Overall Indicators

Total land area	8381 m2
DC Building area	1195 m2
Total IT power	3488 kW
IT liquid cooling rack	50 kW/rack, 16 racks/module, 64 racks in total
Network rack	12 kW/rack, 6 racks/module, 24 racks in total
Design grade	Tier III
IT/Cooling power backup	10 min
Reference PUE	1.13

Design Overview

IT Load - 4360 kW

5 modules | 872 kW/module | 50 kW/cluster





Overall Indicators

Total land area	8381 m2
DC Building area	1403 m2
Total IT power	4360 kW
IT liquid cooling rack	50 kW/rack, 16 racks/module, 80 racks in total
Network rack	12 kW/rack, 6 racks/module, 30 racks in total
Design grade	Tier III
IT/Cooling power backup	10 min
Reference PUE	1.13

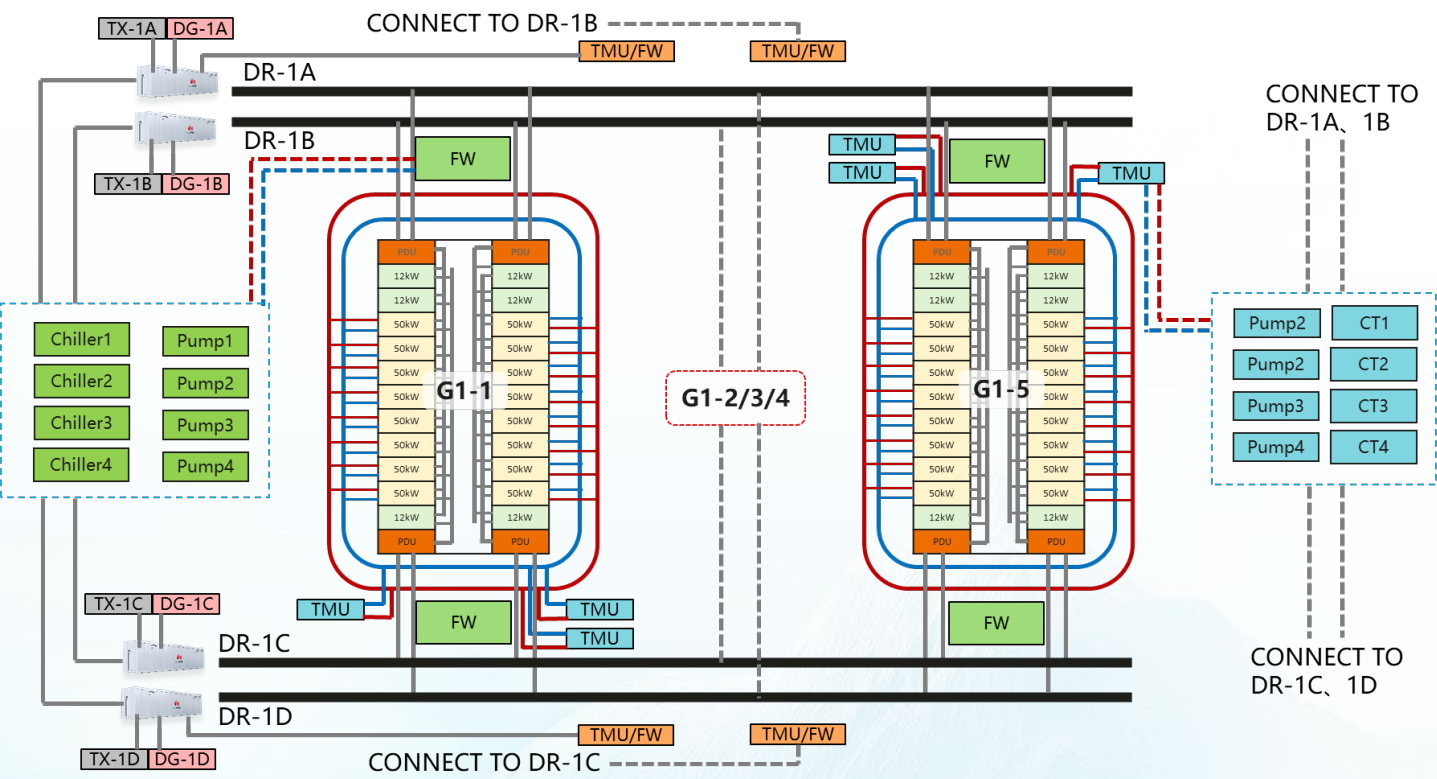
Block diagram

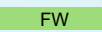
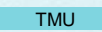

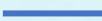
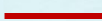
	Outdoor PowerPOD		Chilled Water Fan Wall		Thermal Management Unit
	Power Distribution Unit		Liquid supply		Liquid Return

Power system

Cooling system

Architecture*	4DR
Power module	2.4MW*4
Transformer	2500 kVA*4
Diesel generator	2400 kW DCC*8
PDU	(630 A x 2) x 4 units/module

Air-to-liquid ratio	3:7 (1:9-3:7)
Fan wall	210 kW/set, 10 + 2
TMU	360 kW, (2 + 1) * 5
Cooling tower	124 m³/h, 3 + 1
Air-cooled chiller	625 kW, 3 + 1

* Note: Power distribution architecture supports 2N, DR, and BR.

Design Overview

IT Load - 5232 kW

6 modules | 872 kW/module | 50 kW/rack



Overall Indicators

Total land area	9526 m2
DC Building area	1611 m2
Total IT power	5232 kW
IT liquid cooling rack	50 kW/rack, 16 racks/module, 96 racks in total
Network rack	12 kW/rack, 6 racks/module, 36 racks in total
Design grade	Tier III
IT/Cooling power backup	10 min
Reference PUE	1.13

Block diagram

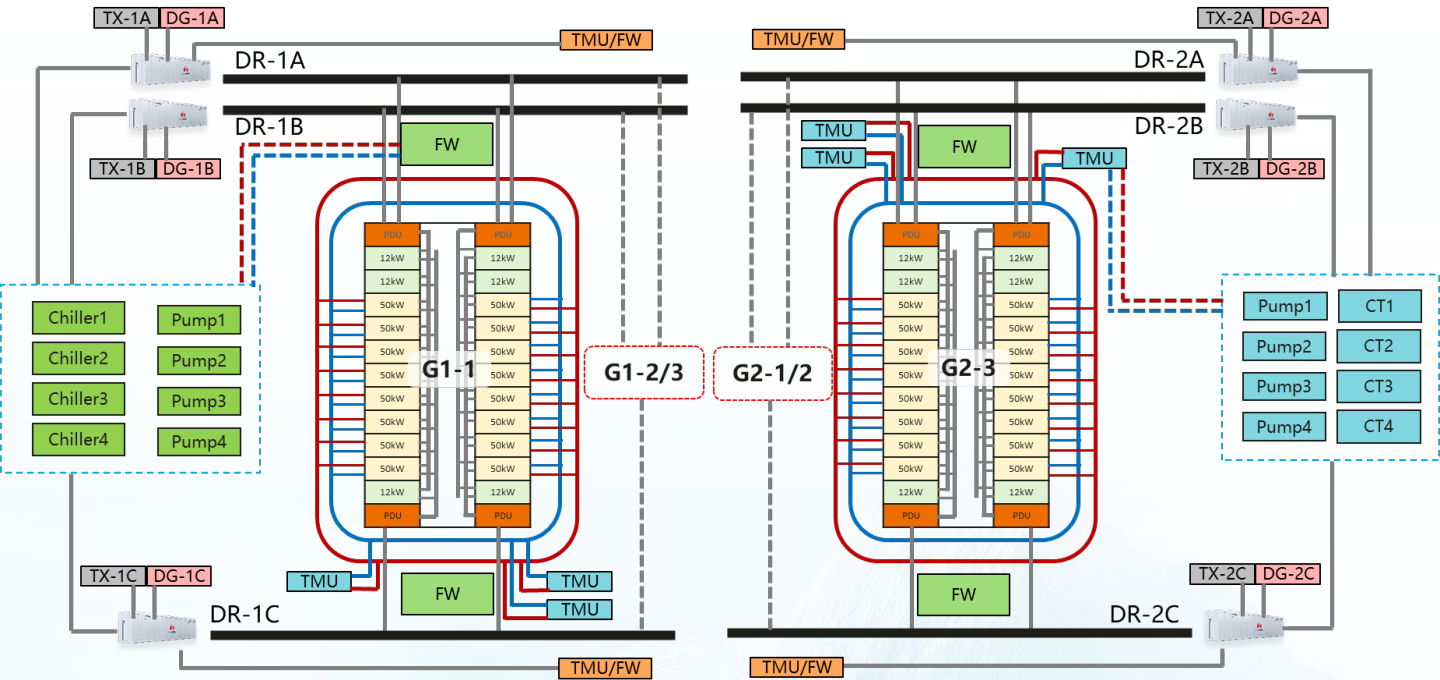

Note: One 3DR power distribution architecture is configured for every 3 modules.

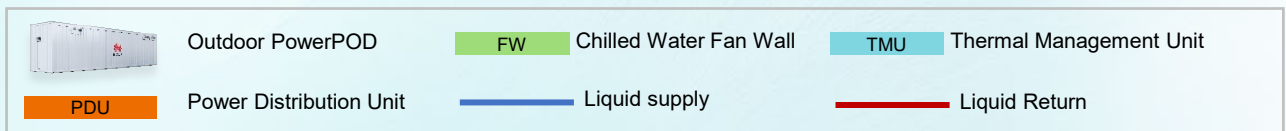

Power system

Architecture*	3DR*2
Power module	2.4MW*6
Transformer	2500 kVA*6
Diesel generator	2200 kW DCC*6
PDU	(630 A x 2) x 4 units/module

Cooling system

Air-to-liquid ratio	3:7 (1:9-3:7)
Fan wall	210 kW/set, 11 + 2
TMU	360 kW, (2 + 1) * 6
Cooling tower	149 m ³ /h, 3 + 1
Air-cooled chiller	750 kW, 3 + 1

* Note: Power distribution architecture supports 2N, DR, and BR.

Design Overview

IT Load - 2384 kW

2 modules | 1192 kW/module | 50 kW/rack



Overall Indicators

Total land area	7758 m2
DC Building area	974 m2
Total IT power	2384 kW
IT liquid cooling rack	70 kW/rack, 16 racks/module, 32 racks in total
Network rack	12 kW/rack, 6 racks/module, 12 racks in total
Design grade	Tier III
IT/Cooling power backup	10 min
Reference PUE	1.13

Block diagram

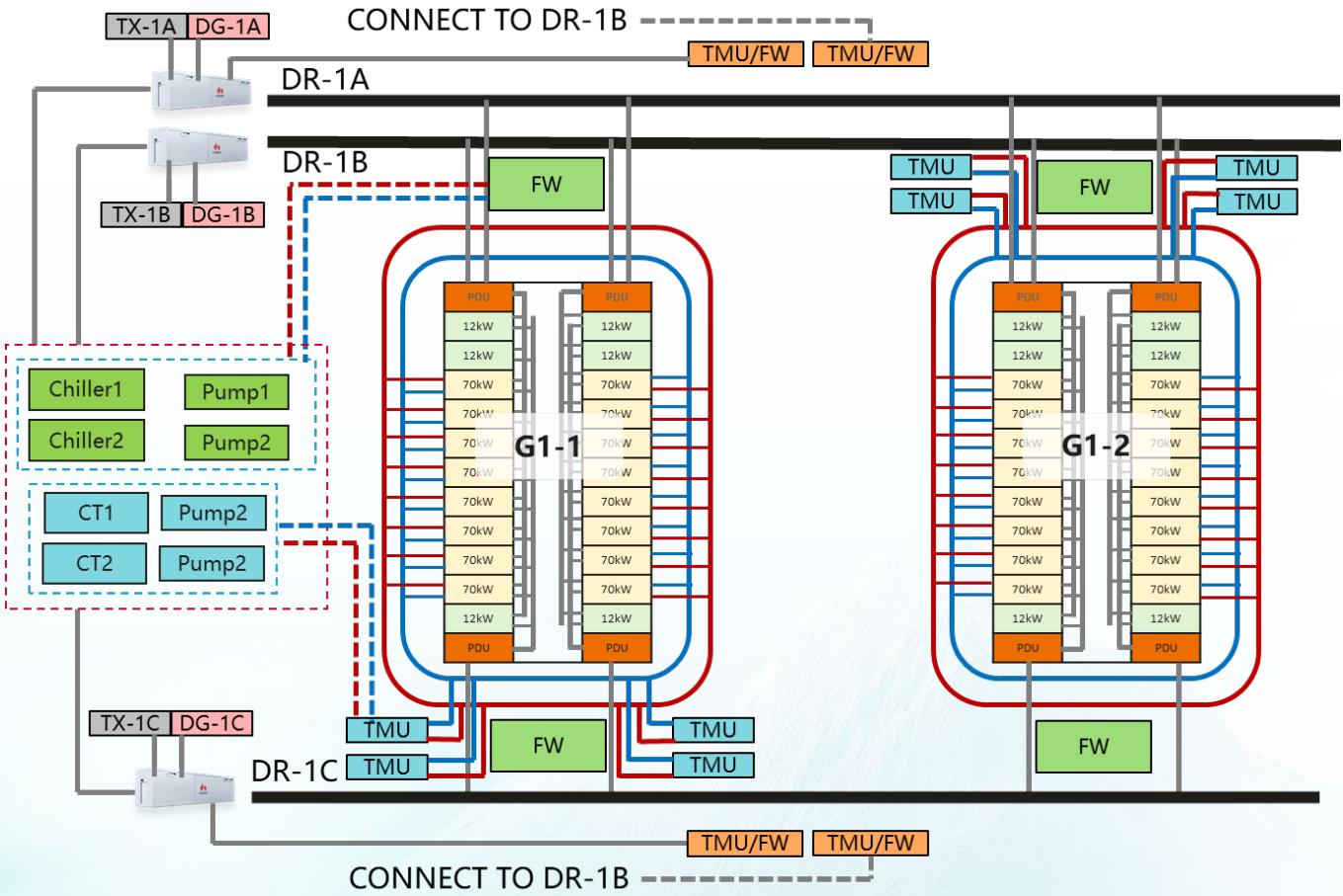

	Outdoor PowerPOD		Chilled Water Fan Wall		Thermal Management Unit
	Power Distribution Unit		Liquid supply		Liquid Return

Power system

Cooling system

Architecture*	3DR
Power module	2.4MW*3
Transformer	2500 kVA*3
Diesel generator	2200 kW DCC*3
PDU	(630 A x 2) x 4 units/module

Air-to-liquid ratio	2:8 (1:9-3:7)
Fan wall	210 kW/set, 4 + 1
TMU	360 kW, (3 + 1) * 2
Cooling tower	238 m ³ /h, 1 + 1
Air-cooled chiller	750 kW, 1 + 1

* Note: Power distribution architecture supports 2N, DR, and BR.

Design Overview

IT Load - 3576 kW

3 modules | 1192 kW/module | 70 kW/cluster



Overall Indicators

Total land area	8381 m2
DC Building area	1176 m2
Total IT power	3576 kW
IT liquid cooling rack	70 kW/rack, 16 racks/module, 48 racks in total
Network rack	12 kW/rack, 6 racks/module, 18 racks in total
Design grade	Tier III
IT/Cooling power backup	10 min
Reference PUE	1.13

Block diagram

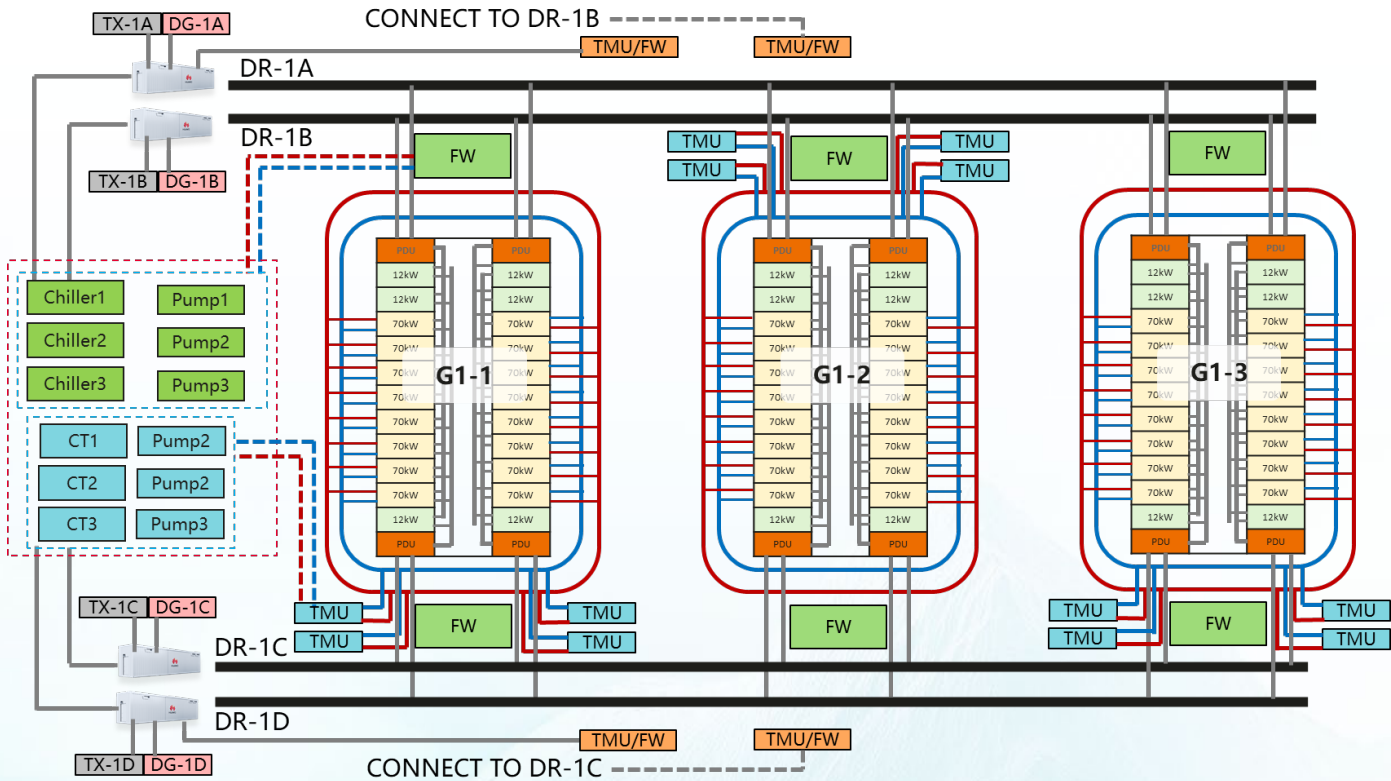

Outdoor PowerPOD

FW

Chilled Water Fan Wall

TMU

Thermal Management Unit

PDU

Power Distribution Unit

Liquid supply

Liquid Return

Power system

Architecture*	4DR
Power module	2.4MW*4
Transformer	2500 kVA*4
Diesel generator	2200 kW DCC*4
PDU	(630 A x 2) x 4 units/module

Cooling system

Air-to-liquid ratio	2:8 (1:9-3:7)
Fan wall	210 kW/set, 6 + 2
TMU	360 kW, (3 + 1) * 6
Cooling tower	179 m ³ /h, 2 + 1
Air-cooled chiller	503 kW, 2 + 1

* Note: Power distribution architecture supports 2N, DR, and BR.

Design Overview

IT Load - 4768 kW

4 modules | 1192 kW/module | 70 kW/rack



Overall Indicators

Total land area	9526 m2
DC Building area	1195 m2
Total IT power	4768 kW
IT liquid cooling rack	70 kW/rack, 16 racks/module, 64 racks in total
Network rack	12 kW/rack, 6 racks/module, 24 racks in total
Design grade	Tier III
IT/Cooling power backup	10 min
Reference PUE	1.13

Block diagram

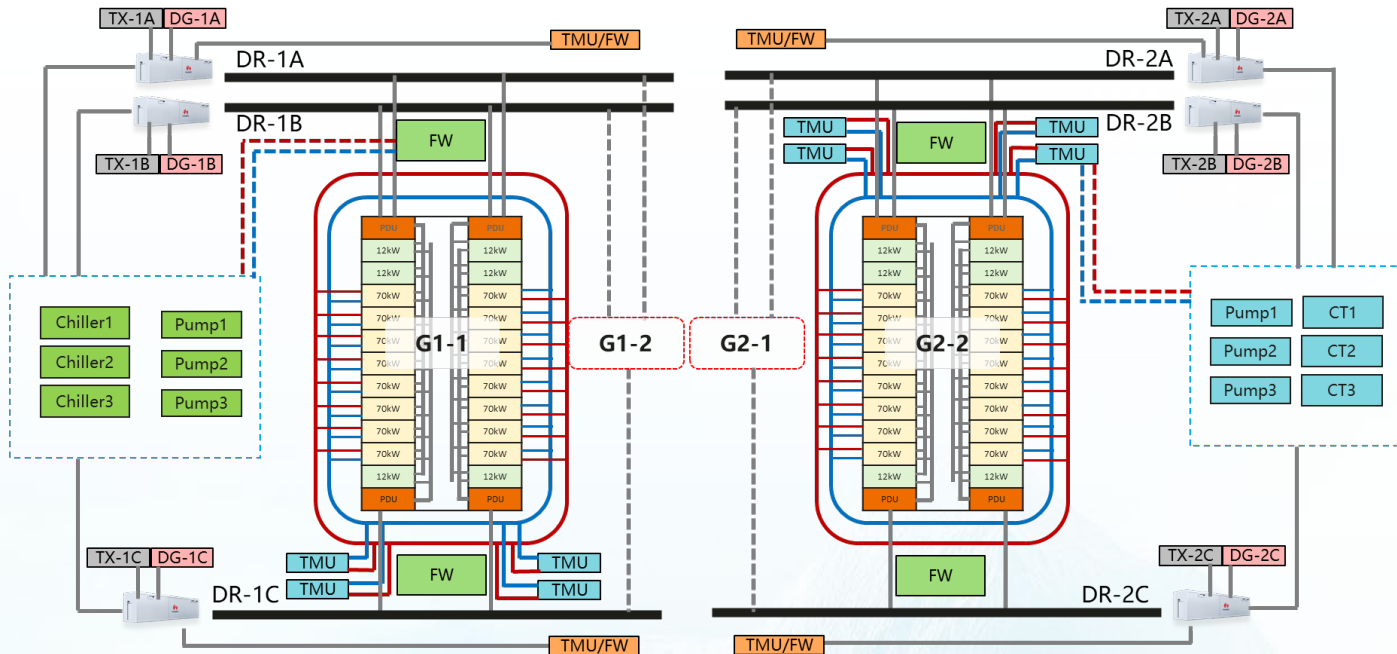

Note: One 3DR power distribution architecture is configured for every 2 modules.

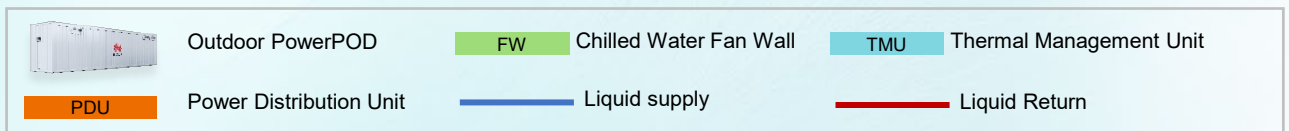

Power system

Architecture*	3DR*2
Power module	2.4MW*6
Transformer	2500 kVA*6
Diesel generator	2200 kW DCC*6
PDU	(630 A x 2) x 4 units/module

Cooling system

Air-to-liquid ratio	2:8 (1:9-3:7)
Fan wall	210 kW/set, 7 + 2
TMU	450 kW, (3 + 1) * 4
Cooling tower	238 m ³ /h, 2 + 1
Air-cooled chiller	750 kW, 2 + 1

* Note: Power distribution architecture supports 2N, DR, and BR.

Design Overview

IT Load - 5960 kW

5 modules | 1192 kW/module | 70 kW/rack



Overall Indicators

Total land area	11340 m2
DC Building area	1403 m2
Total IT power	5960 kW
IT liquid cooling rack	70 kW/rack, 16 racks/module, 80 racks in total
Network rack	12 kW/rack, 6 racks/module, 30 racks in total
Design grade	Tier III
IT/Cooling power backup	10 min
Reference PUE	1.13

Block diagram

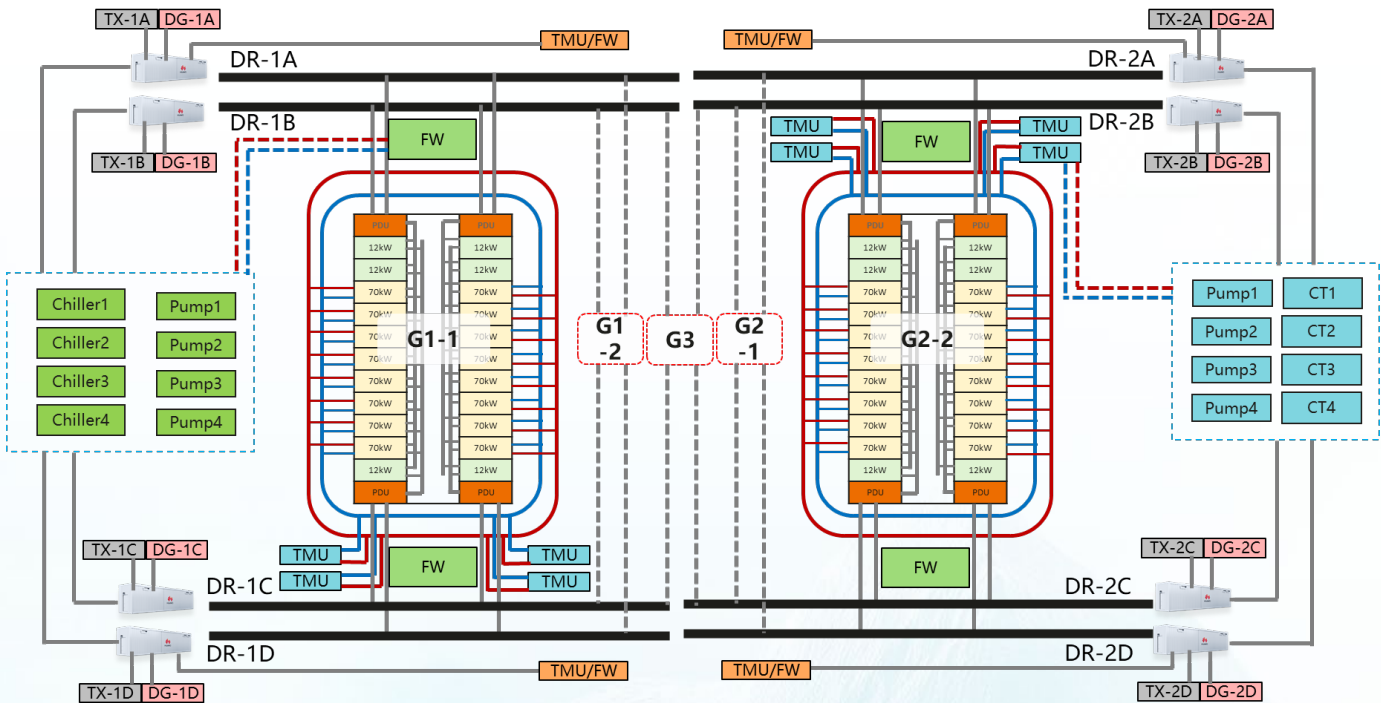

Note: One 4DR power distribution architecture is configured for every 2.5 modules.

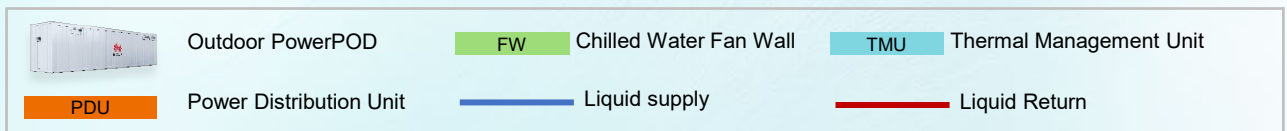

Power system

Architecture*	4DR*2
Power module	1.8MW*8
Transformer	2000 kVA*8
Diesel generator	2000 kW DCC*8
PDU	(630 A x 2) x 4 units/module

Cooling system

Air-to-liquid ratio	2:8 (1:9-3:7)
Fan wall	210 kW/set, 9 + 2
TMU	360 kW, (3 + 1) * 5
Cooling tower	199 m ³ /h, 3 + 1
Air-cooled chiller	625 kW, 3 + 1

* Note: Power distribution architecture supports 2N, DR, and BR.

Design Overview

IT Load - 7152 kW

6 modules | 1192 kW/module | 70 kW/rack





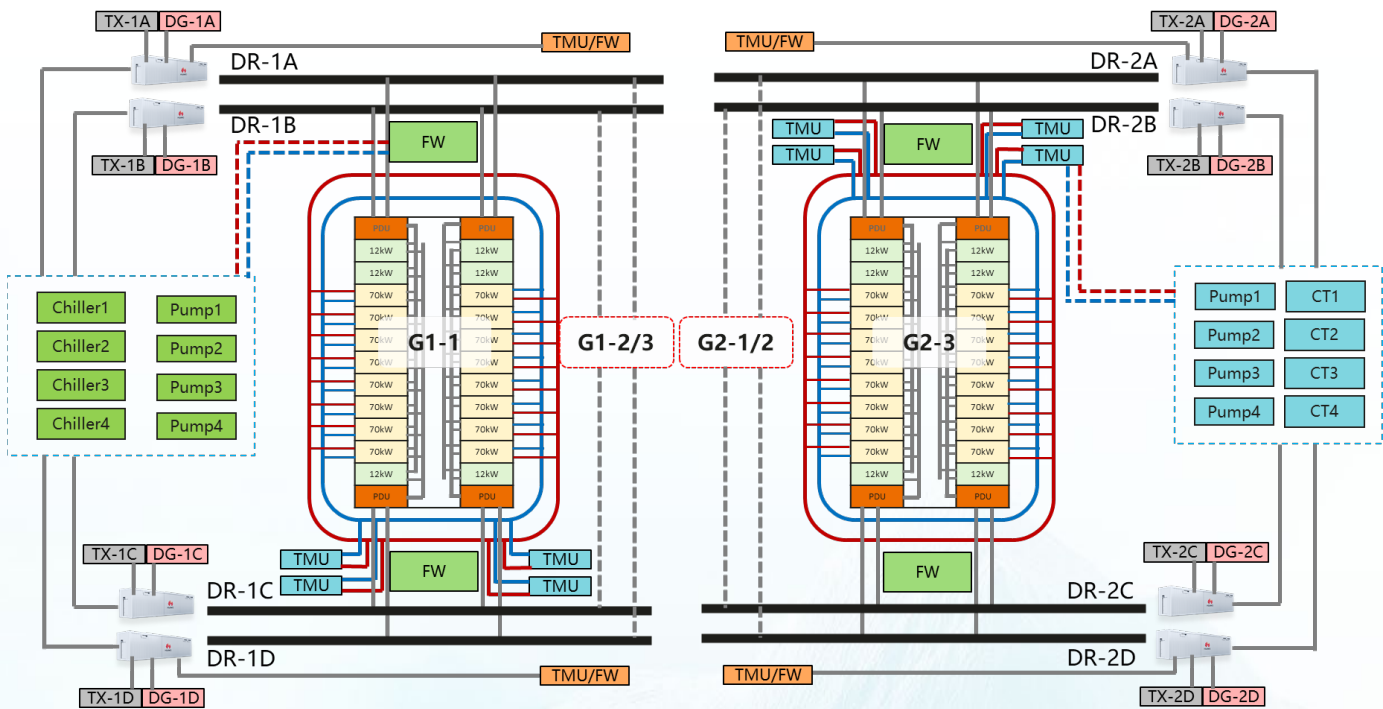

Overall Indicators

Total land area	11340 m2
DC Building area	1611 m2
Total IT power	7152 kW
IT liquid cooling rack	70 kW/rack, 16 racks/module, 96 racks in total
Network rack	12 kW/rack, 6 racks/module, 36 racks in total
Design grade	Tier III
IT/Cooling power backup	10 min
Reference PUE	1.13

Block diagram

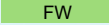
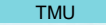

Note: One 4DR power distribution architecture is configured for every 3 modules.

	Outdoor PowerPOD		Chilled Water Fan Wall		Thermal Management Unit
	Power Distribution Unit		Liquid supply		Liquid Return

Power system

Cooling system

Architecture*	4DR*2
Power module	2.4MW*8
Transformer	2500 kVA*8
Diesel generator	2200 kW DCC*8
PDU	(630 A x 2) x 4 units/module

Air-to-liquid ratio	2:8 (1:9-3:7)
Fan wall	210 kW/set, 11 + 2
TMU	360 kW, (3 + 1) * 6
Cooling tower	238 m ³ /h, 3 + 1
Air-cooled chiller	750 kW, 3 + 1

* Note: Power distribution architecture supports 2N, DR, and BR.

Design Overview

IT Load - 3528 kW

3 modules | 1176 kW/module | 132 kW/rack



Overall Indicators

Total land area	8381 m2
DC Building area	1176 m2
Total IT power	3528 kW
IT liquid cooling rack	132 kW/rack, 8 racks/module, 24 racks in total
Network rack	12 kW/rack, 10 racks/module, 30 racks in total
Design grade	Tier III
IT/Cooling power backup	10 min
Reference PUE	1.13

Block diagram

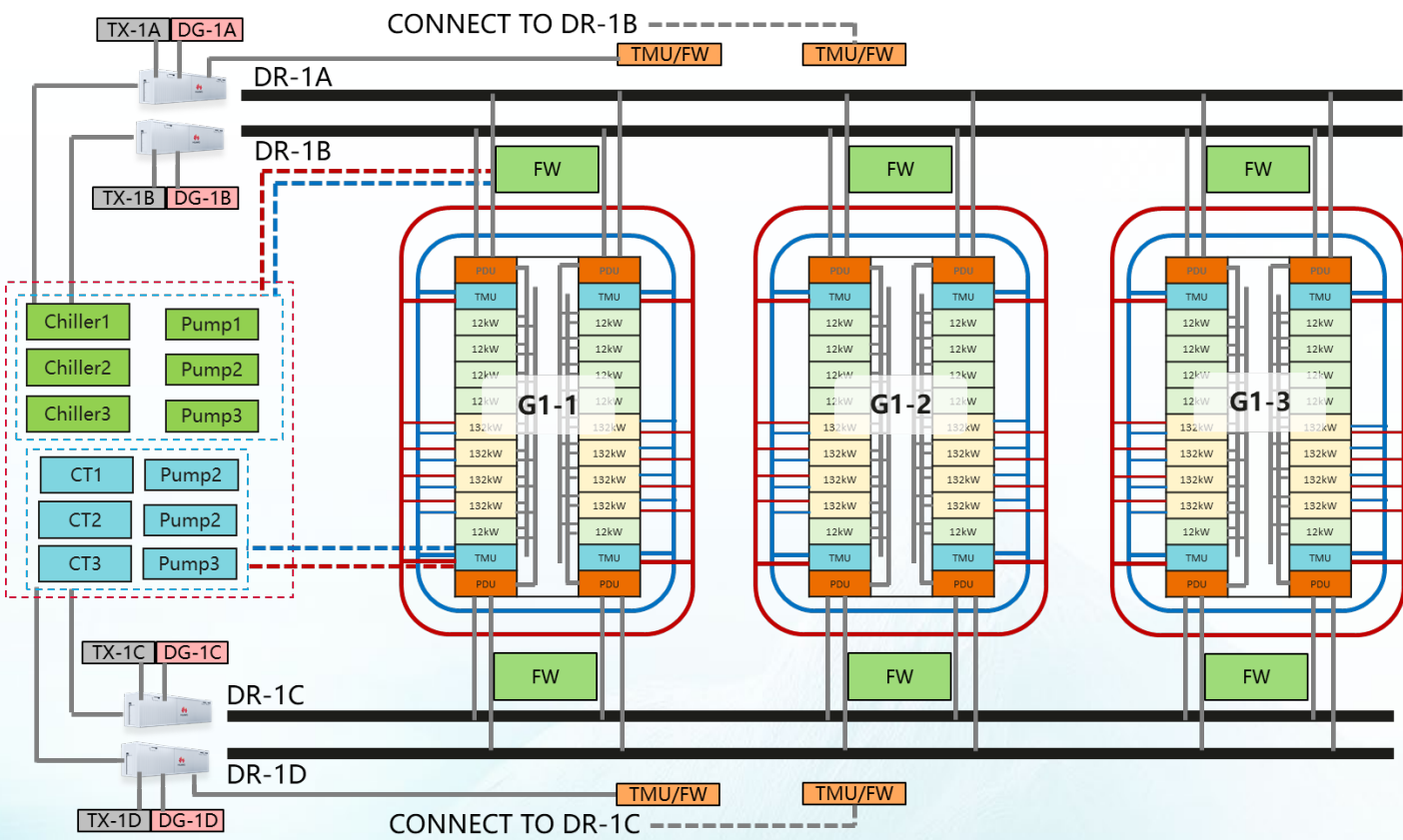

	Outdoor PowerPOD		FW Chilled Water Fan Wall		TMU Thermal Management Unit
	PDU Power Distribution Unit		Liquid supply		Liquid Return

Power system

Architecture*	4DR
Power module	2.4MW*4
Transformer	2500 kVA*4
Diesel generator	2200 kW DCC*4
PDU	(630 A x 2) x 4 units/module

Cooling system

Air-to-liquid ratio	2:8 (1:9-3:7)
Fan wall	210 kW/set, 6 + 2
TMU	360 kW, (3 + 1) * 3
Cooling tower	169 m³/h, 2 + 1
Air-cooled chiller	625 kW, 2 + 1

* Note: Power distribution architecture supports 2N, DR, and BR.

Design Overview

IT Load - 4704 kW

4 modules | 1176 kW/module | 132 kW/rack



Overall Indicators

Total land area	9526 m2
DC Building area	1195 m2
Total IT power	4704 kW
IT liquid cooling rack	132 kW/rack, 8 racks/module, 32 racks in total
Network rack	12 kW/rack, 10 racks/module, 40 racks in total
Design grade	Tier III
IT/Cooling power backup	10 min
Reference PUE	1.13

Block diagram

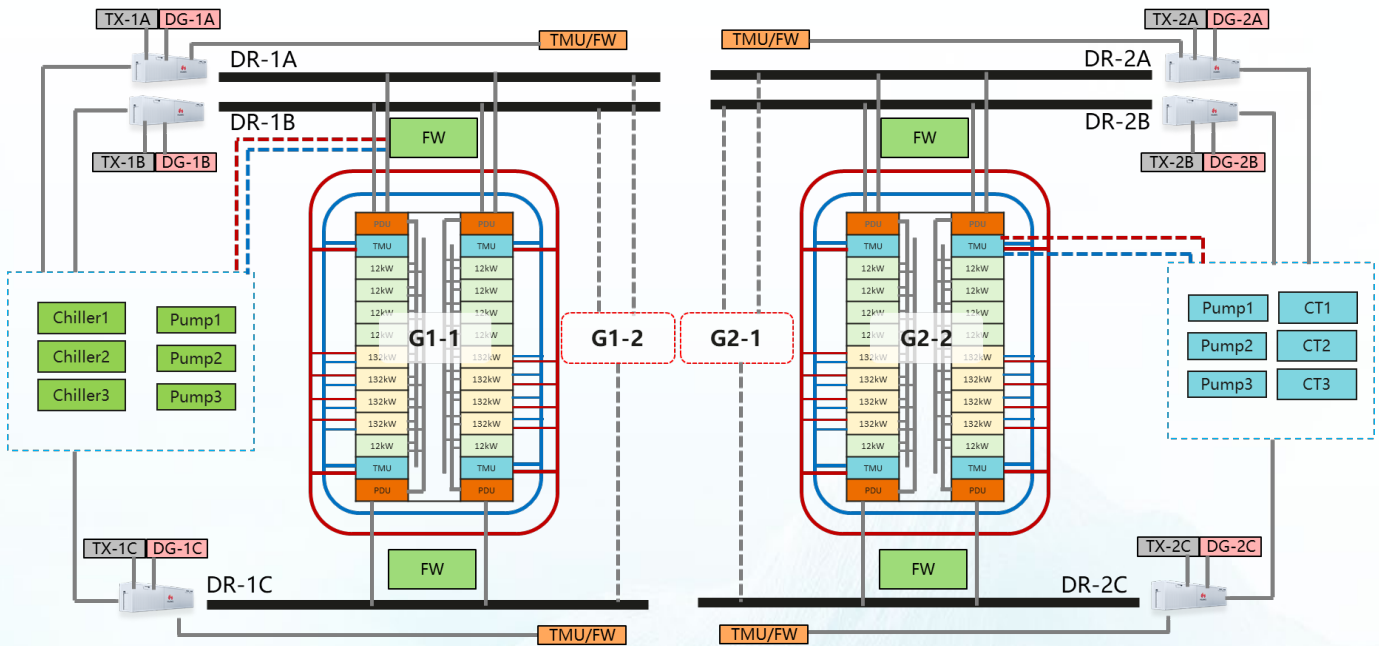

Note: One 3DR power distribution architecture is configured for every 2 modules.

	Outdoor PowerPOD		Chilled Water Fan Wall		Thermal Management Unit
	Power Distribution Unit		Liquid supply		Liquid Return

Power system

Cooling system

Architecture*	3DR*2
Power module	2.4 MW*6
Transformer	2500 kVA*6
Diesel generator	2200 kW DCC*6
PDU	(630 A x 2) x 4 units/module

Air-to-liquid ratio	2:8 (1:9-3:7)
Fan wall	210 kW/set, 8 + 2
TMU	360 kW, (3 + 1) * 4
Cooling tower	225 m ³ /h, 2 + 1
Air-cooled chiller	750 kW, 2 + 1

* Note: Power distribution architecture supports 2N, DR, and BR.

Design Overview

IT Load - 5880 kW

5 modules | 1176 kW/module | 132 kW/rack



Overall Indicators

Total land area	11340 m2
DC Building area	1403 m2
Total IT power	5880 kW
IT liquid cooling rack	132 kW/rack, 8 racks/module, 40 racks in total
Network rack	12 kW/rack, 10 racks/module, 50 racks in total
Design grade	Tier III
IT/Cooling power backup	10 min
Reference PUE	1.13

Block diagram

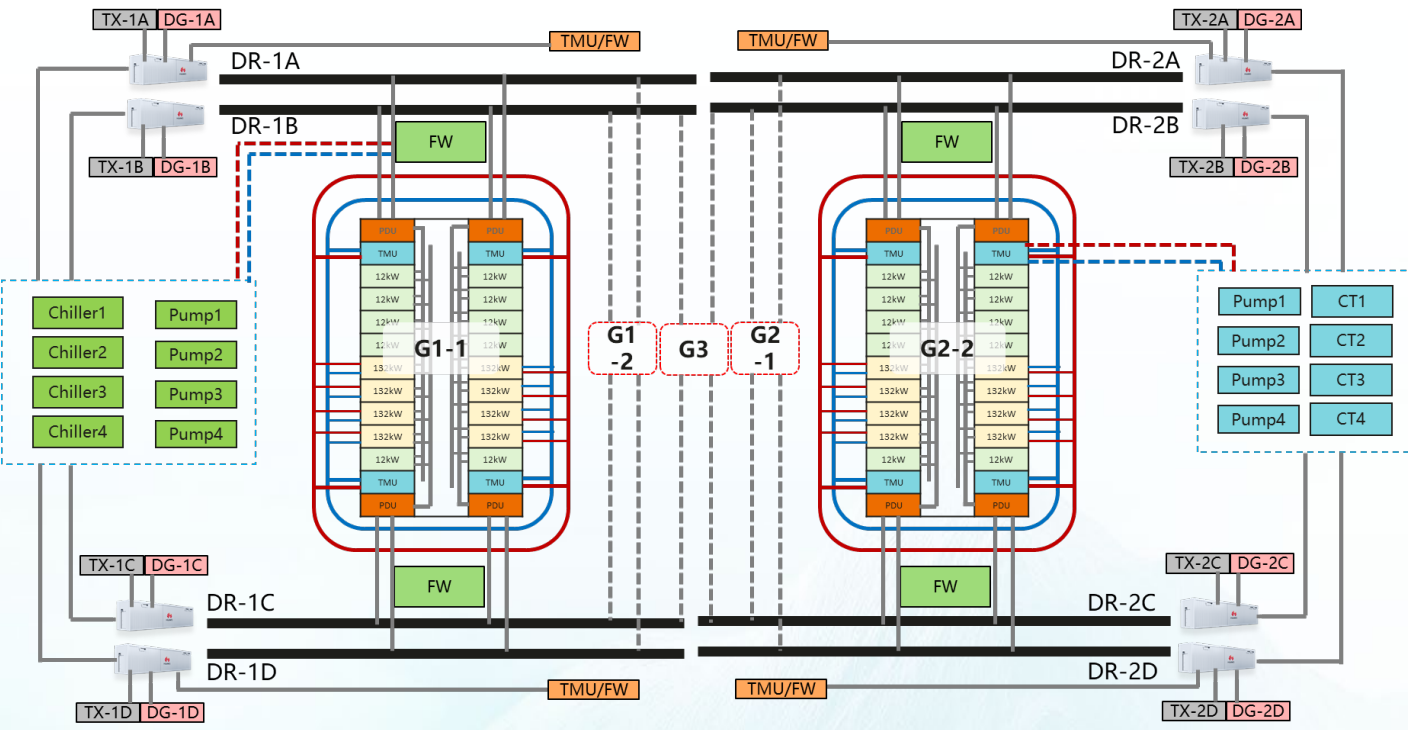

Note: One 4DR power distribution architecture is configured for every 2.5 modules.

	Outdoor PowerPOD		Chilled Water Fan Wall		Thermal Management Unit
	Power Distribution Unit		Liquid supply		Liquid Return

Power system	
Architecture*	4DR*2
Power module	1.8MW*8
Transformer	2000 kVA*8
Diesel generator	2000 kW DCC*8
PDU	(630 A x 2) x 4 units/module

Cooling system	
Air-to-liquid ratio	2:8 (1:9-3:7)
Fan wall	210 kW/set, 10 + 2
TMU	360 kW, (3 + 1) * 5
Cooling tower	187 m³/h, 3 + 1
Air-cooled chiller	625 kW, 3 + 1

* Note: Power distribution architecture supports 2N, DR, and BR.

Design Overview

IT Load - 7056 kW

6 modules | 1176 kW/module | 132 kW/rack







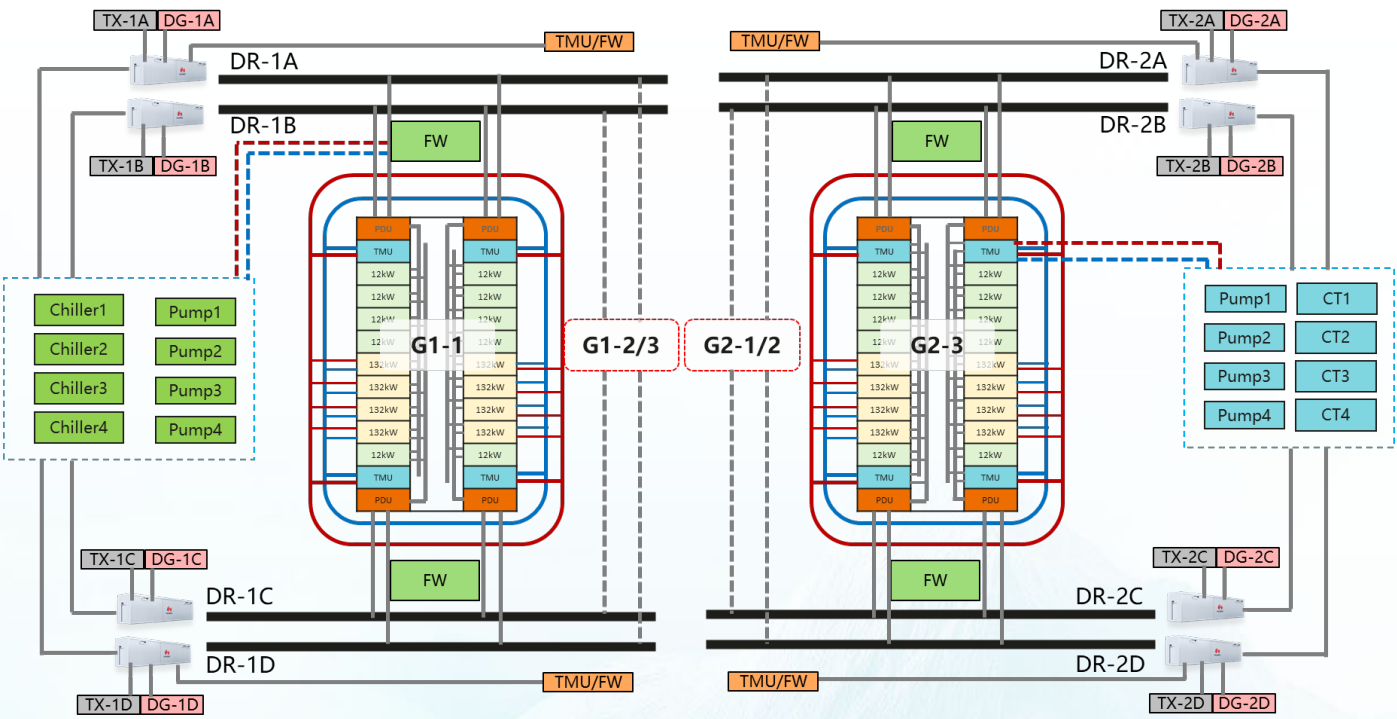

Overall Indicators

Total land area	11340 m2
DC Building area	1610 m2
Total IT power	7056 kW
IT liquid cooling rack	132 kW/rack, 8 racks/module, 48 racks in total
Network rack	12 kW/rack, 10 racks/module, 60 racks in total
Design grade	Tier III
IT/Cooling power backup	10 min
Reference PUE	1.13

Block diagram



Note: One 4DR power distribution architecture is configured for every 3modules.

	Outdoor PowerPOD		Chilled Water Fan Wall		Thermal Management Unit
	Power Distribution Unit		Liquid supply		Liquid Return

Power system

Architecture*	4DR*2
Power module	2.4vMW*8
Transformer	2500 kVA*8
Diesel generator	2200 kW DCC*8
PDU	(630 A x 2) x 4 units/module

Cooling system

Air-to-liquid ratio	2:8 (1:9-3:7)
Fan wall	210 kW/set, 12 + 2
TMU	360 kW, (3 + 1) * 6
Cooling tower	225 m ³ /h, 3 + 1
Air-cooled chiller	750 kW, 3 + 1

* Note: Power distribution architecture supports 2N, DR, and BR.

Steel structure solution

Solution Overview

IT rack: 50 kW/rack, 70 kW/rack, 132 kW/rack
Capacity coverage: 15 MW-50 MW



CFD

Circuit simulation

Cost evaluation

Structural Analysis

PUE Calculation

PIP Template

Features and Benefits

- Integrated Design** End-to-end design for power system, cooling system, campus layout, office areas, and auxiliary systems
- Modular Design** Flexible data center size, easy installation of core modules, ultra-large single-unit capacity
- High Reliability** Distributed deployment of power and cooling system, no spread of single-unit failures
- High Feasibility*** Leading regional cost baseline, PIP ≤ 12 Months

Module Overview

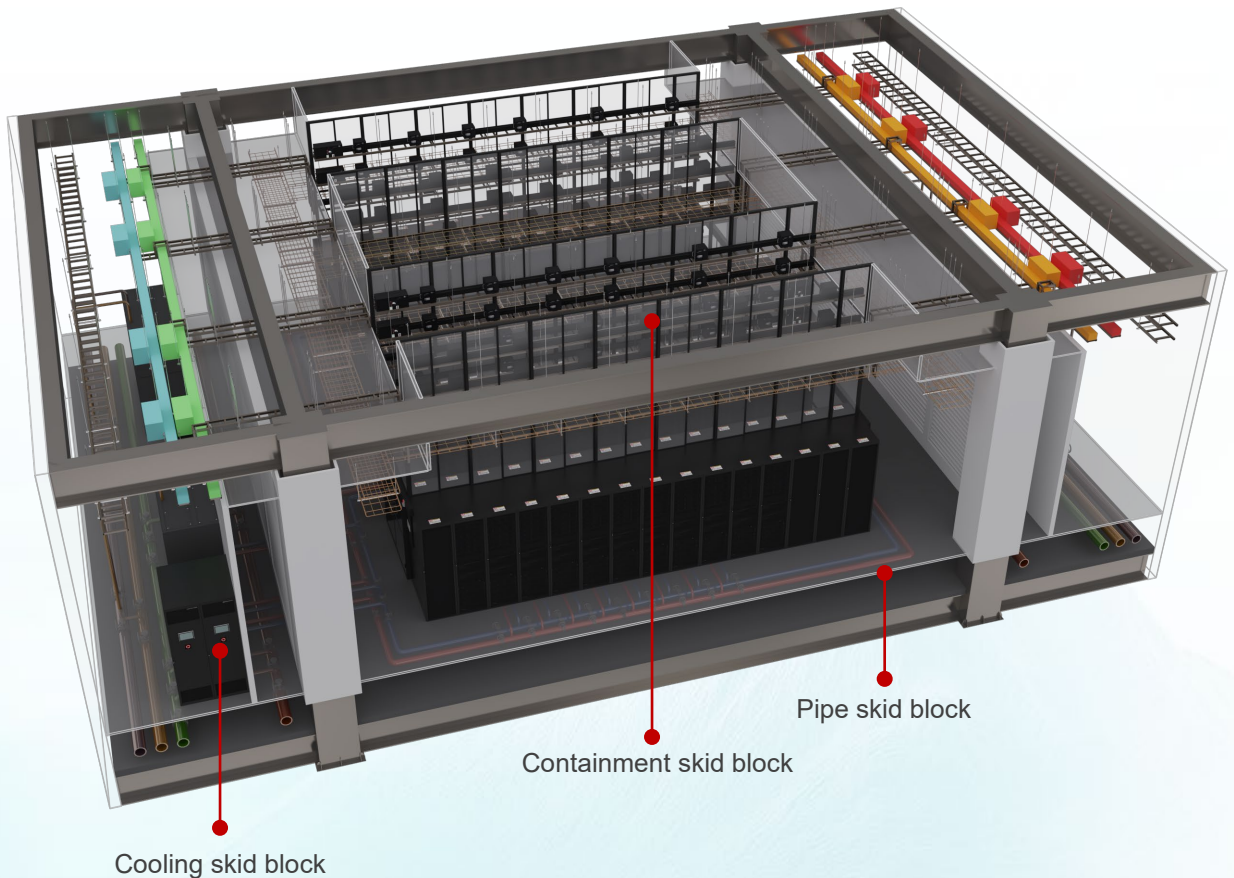

Module Design

Standard structure	Large column spacing (14 m x 14 m), large storey height (≥ 6.5 m), and standardized functional rooms
Cooling skid block	TMU Thermal management unit, water-cooled fan wall, and primary loop
Containment skid block	Hot aisle containment, busbar, cable tray, and integrated cabling system
Pipe skid block	Secondary loop, valve, instrument, water leakage detection, etc.

Remarks:

1. Pipes can be deployed from top or bottom.
2. rack power distribution supports busbars or PDCs.

Design Overview

IT Load: 15.2MW@50 kW/rack

AI: 16 modules | 872 kW/module | 3488 kW/hall | 14 MW/cluster
Common: 4 modules | 300 kW/module | 600 kW/hall | 1.2 MW/cluster



Overall Indicators





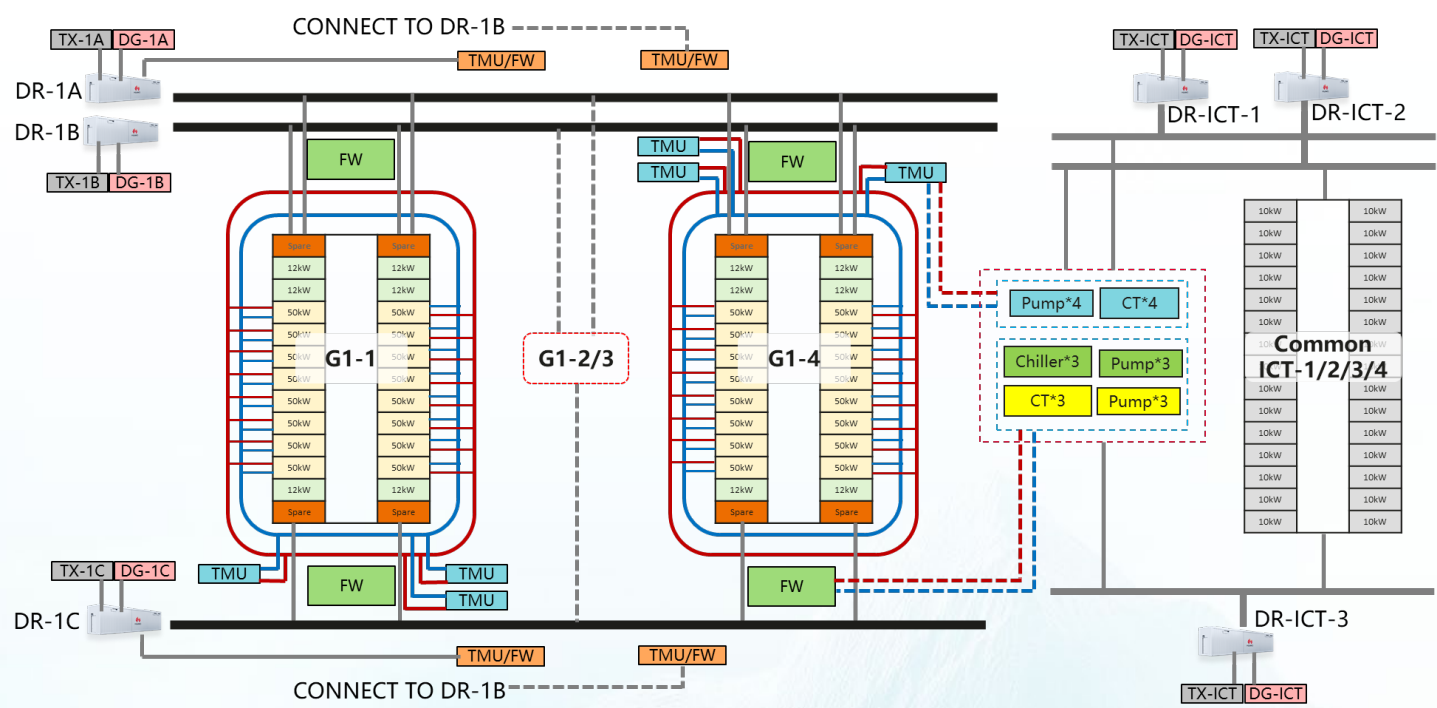

Total land area	13440 m2
DC Building area	5450 m2 (Excluding the area of steel platform and cooling station)
Total IT power	15.2 MW
IT liquid cooling rack	50 kW/rack, 16 racks/module, 256 in total
Network rack	12 kW/rack, 6 racks/module, 96 racks in total
Common rack	10 kW/rack, 30 racks/module, 120 racks in total
Design grade	Tier III
IT/Cooling power backup	10 min
Reference PUE	1.13

Block diagram

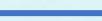

Remarks:

1. One set of 3DR power distribution architecture is configured for every 4 modules, total 4 sets
2. Common ICT and mechanical devices share a 3DR power distribution architecture.

	Outdoor PowerPOD		Fan Wall		Thermal Management Unit
	Diesel Generator		Liquid supply		Liquid Return

Power system

Architecture*	IT: 3DR*4 Common+ME: 3DR
Power module	IT: 3.0MW*12 Common+ME: 1.8MW*3
Transformer	2500 kVA*15
Diesel generator	2400 kW DCC*15
Busbar	630A

Cooling system

Air-to-liquid ratio	3:7 (1:9-3:7) Common: 100% air
Fan wall/hall	IT: 210 kW*(8+2) Common: 210 kW*(4+1)
TMU/hall	360 kW/set, (2+1) *4
Cooling tower	397 m ³ /h, 3+1
Chiller	3517 kW, 2+1

* Note: Power distribution architecture supports 2N, DR, and BR.

Design Overview

IT Load: 33.8 MW@50 kW/rack

AI: 36 modules | 872 kW/module | 5232 kW/hall | 31.4 MW/cluster
Common : 8 modules | 300 kW/module | 600 kW/hall | 2.4 MW/cluster



Overall Indicators





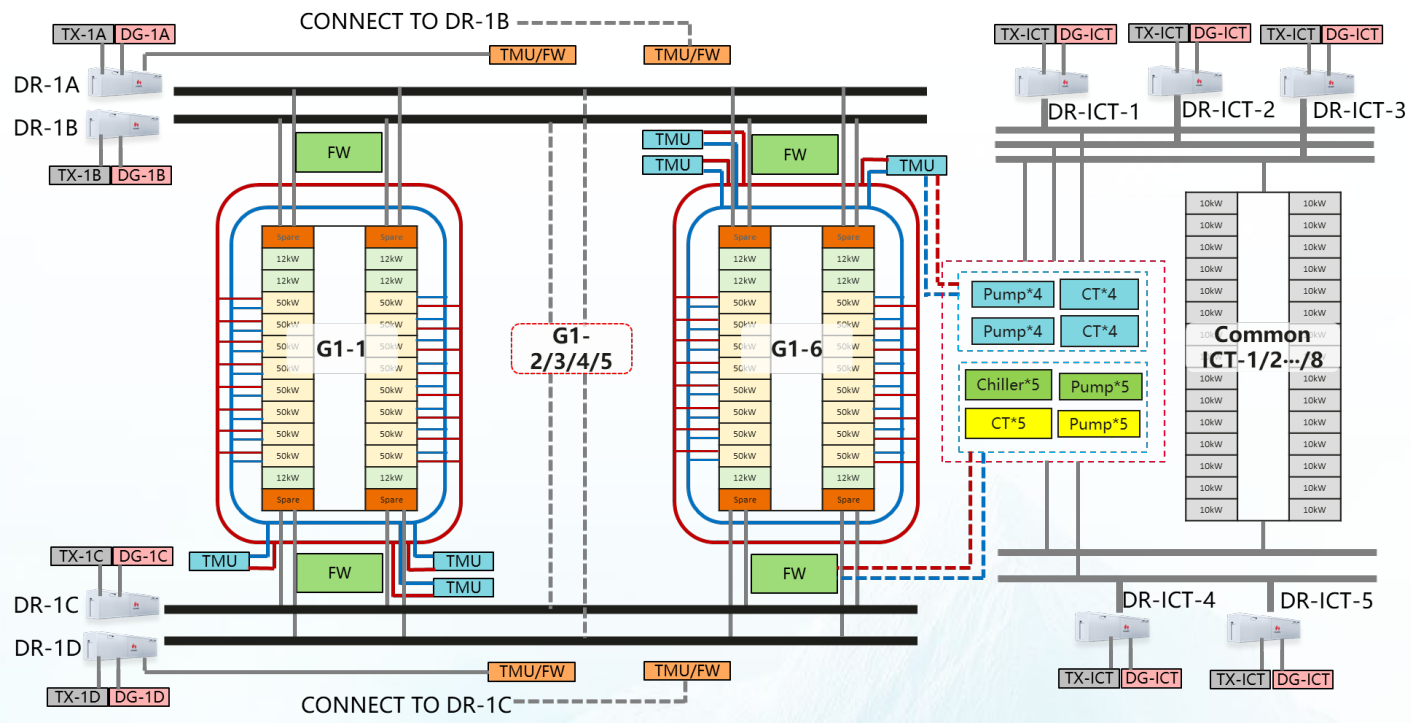

Total land area	15140 m ²
DC Building area	9996 m ² (Excluding the area of steel platform and cooling station)
Total IT power	33.8 MW
IT liquid cooling rack	50 kW/rack, 16 racks/module, 576 in total
Network rack	12 kW/rack, 6 racks/module, 216 racks in total
Common rack	10 kW/rack, 30 racks/module, 240 racks in total
Design grade	Tier III
IT/Cooling power backup	10 min
Reference PUE	1.13

Block diagram

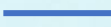

Remarks:

1. One set of 4DR power distribution architecture is configured for every 6 modules, total 6 sets
2. Common ICT and mechanical devices share a 5DR power distribution architecture.

	Outdoor PowerPOD		Fan Wall		Thermal Management Unit
	Diesel Generator		Liquid supply		Liquid Return

Power system

Cooling system

Architecture*	IT: 4DR*6 Common+ME: 5DR	Air-to-liquid ratio	3:7 (1:9-3:7) Common: 100% air
Power module	IT: 3.0MW*12 Common+ME: 1.8MW*5	Fan wall/hall	IT: 210 kW*(11+2) Common: 210 kW*(4+1)
Transformer	2500 kVA*29	TMU/hall	360 kW/set, (2+1) *6
Diesel generator	2400 kW DCC*29	Cooling tower	447 m ³ /h, (3+1)*2
Busbar	630A	Chiller	3869 kW, 4+1

* Note: Power distribution architecture supports 2N, DR, and BR.

Design Overview

IT Load: 33.8 MW@50 kW/rack

AI: 16 modules | 1240 kW/module | 4960 kW/hall | 20 MW/cluster
Common : 4 modules | 300 kW/module | 600 kW/hall | 1.2 MW/cluster



Overall Indicators

Total land area	13440 m2
DC Building area	5450 m2 (Excluding the area of steel platform and cooling station)
Total IT power	21.2 MW
IT liquid cooling rack	70 kW/rack, 16 racks/module, 256 in total
Network rack	12 kW/rack, 10 racks/module, 160 racks in total
Common rack	10 kW/rack, 30 racks/module, 120 racks in total
Design grade	Tier III
IT/Cooling power backup	10 min
Reference PUE	1.13

Block diagram

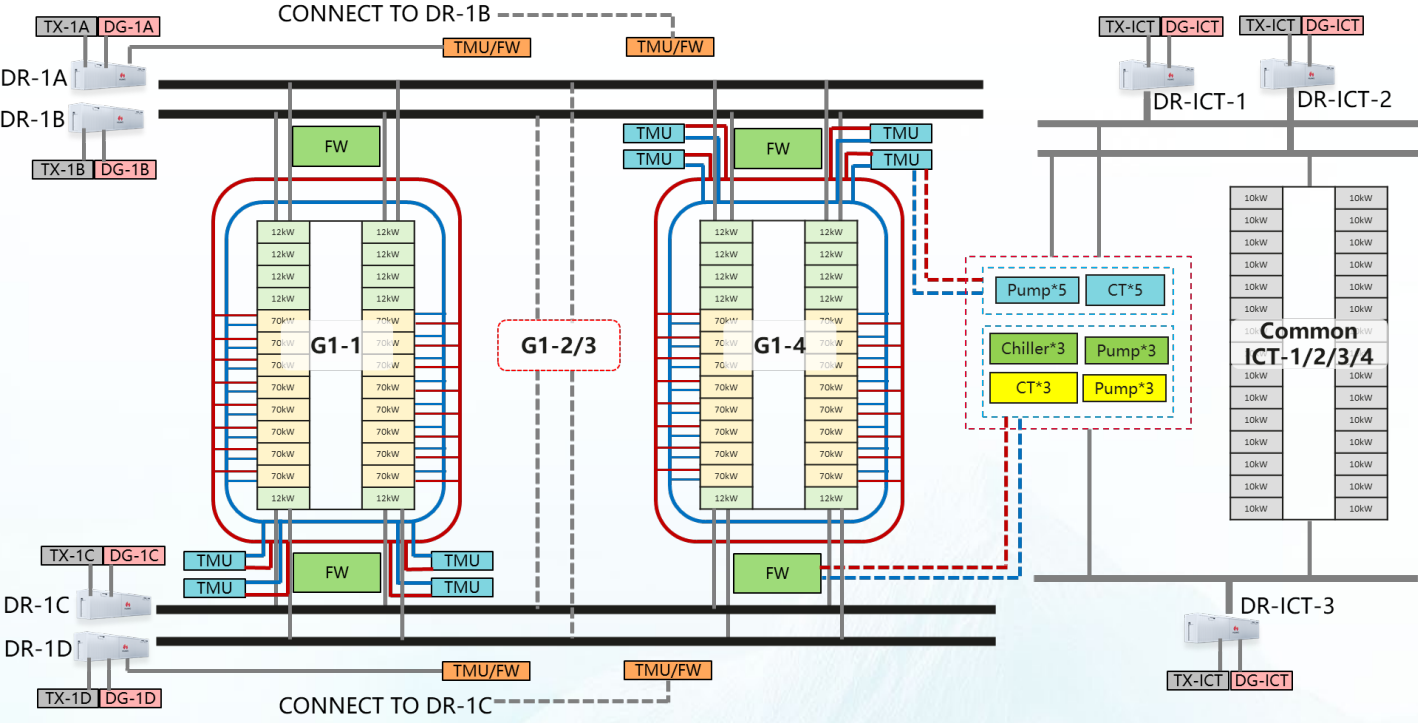

Remarks:

1. One set of 4DR power distribution architecture is configured for every 4 modules, total 4 sets
2. Common ICT and mechanical devices share a 3DR power distribution architecture.

	Outdoor PowerPOD		Fan Wall		Thermal Management Unit
	Diesel Generator		Liquid supply		Liquid Return

Power system		Cooling system	
Architecture*	IT: 4DR*4 Common+ME: 3DR	Air-to-liquid ratio	2:8 (1:9-3:7) Common: 100% air
Power module	IT: 3.0MW*16 Common+ME: 1.8MW*3	Fan wall/hall	IT: 210 kW*(8+2) Common: 210 kW*(4+1)
Transformer	2500 kVA*19	TMU/hall	360 kW/set, (3+1) *4
Diesel generator	2400 kW DCC*19	Cooling tower	447 m³/h, 4+1
Busbar	630A	Chiller	3869 kW, 2+1

* Note: Power distribution architecture supports 2N, DR, and BR.

Design Overview

IT Load: 47 MW@70 kW/rack

AI: 36 modules | 1240 kW/module | 7440 kW/hall | 44.6 MW/cluster
Common : 8 modules | 300 kW/module | 600 kW/hall | 2.4 MW/cluster



Overall Indicators

Total land area	15140 m2
DC Building area	9996 m2 (Excluding the area of steel platform and cooling station)
Total IT power	47 MW
IT liquid cooling rack	70 kW/rack, 16 racks/module, 576 in total
Network rack	12 kW/rack, 10 racks/module, 360 racks in total
Common rack	10 kW/rack, 30 racks/module, 240 racks in total
Design grade	Tier III
IT/Cooling power backup	10 min
Reference PUE	1.13

Block diagram

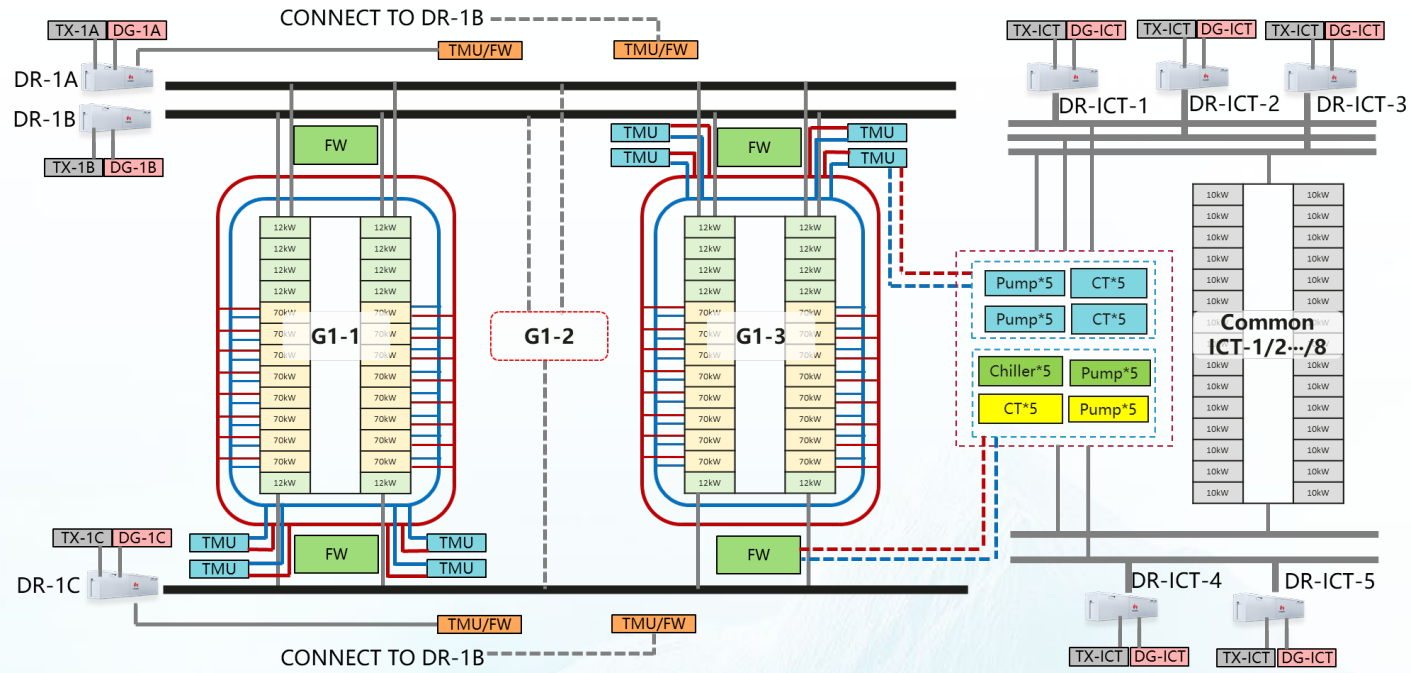

Remarks:

1. One set of 3DR power distribution architecture is configured for every 3 modules, total 12 sets
2. Common ICT and mechanical devices share a 5DR power distribution architecture.

	Outdoor PowerPOD		Fan Wall		Thermal Management Unit
	Diesel Generator		Liquid supply		Liquid Return

Power system

Cooling system

Architecture*	IT: 3DR*12 Common+ME: 5DR	Air-to-liquid ratio	2:8 (1:9-3:7) Common: 100% air
Power module	IT: 3.0MW*36 Common+ME: 1.8MW*5	Fan wall/hall	IT: 210 kW*(12+2) Common: 210 kW*(4+1)
Transformer	2500 kVA*41	TMU/hall	360 kW/set, (3+1) *6
Diesel generator	2400 kW DCC*41	Cooling tower	536 m³/h, (4+1)*2
Busbar	630A	Chiller	4220 kW, 4+1

* Note: Power distribution architecture supports 2N, DR, and BR.

Design Overview

IT Load: 20 MW@132 kW/rack

AI: 16 modules | 1176 kW/module | 4704 kW/hall | 18.8 MW/cluster
Common : 4 modules | 300 kW/module | 600 kW/hall | 1.2 MW/cluster



Overall Indicators





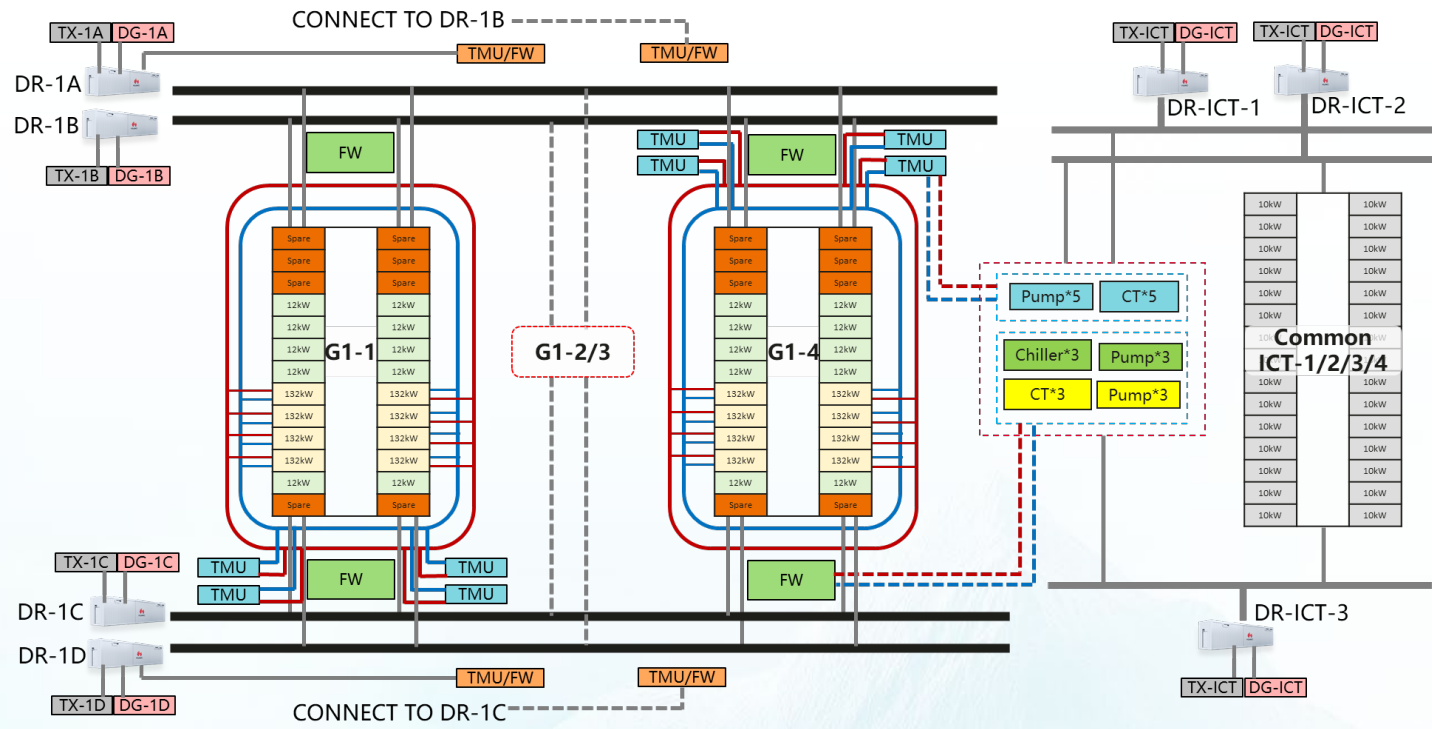

Total land area	13190 m2
DC Building area	5160 m2 (Excluding the area of steel platform and cooling station)
Total IT power	20 MW
IT liquid cooling rack	132 kW/rack, 8 racks/module, 128 in total
Network rack	12 kW/rack, 10 racks/module, 160 racks in total
Common rack	10 kW/rack, 30 racks/module, 120 racks in total
Design grade	Tier III
IT/Cooling power backup	10 min
Reference PUE	1.13

Block diagram

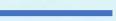

Remarks:

1. One set of 4DR power distribution architecture is configured for every 4 modules, total 4 sets
2. Common ICT and mechanical devices share a 3DR power distribution architecture.

	Outdoor PowerPOD		Fan Wall		Thermal Management Unit
	Diesel Generator		Liquid supply		Liquid Return

Power system

Cooling system

Architecture*	IT: 4DR*4 Common+ME: 3DR	Air-to-liquid ratio	2:8 (1:9-3:7) Common: 100% air
Power module	IT: 3.0MW*16 Common+ME: 1.8MW*3	Fan wall/hall	IT: 210 kW*(8+2) Common: 210 kW*(4+1)
Transformer	2500 kVA*19	TMU/hall	360 kW/set, (3+1) *4
Diesel generator	2400 kW DCC*19	Cooling tower	449 m ³ /h, 4+1
Busbar	630A	Chiller	3869 kW, 2+1

* Note: Power distribution architecture supports 2N, DR, and BR.

Design Overview

IT Load: 44.7 MW@132 kW/rack

AI: 36 modules | 1176 kW/module | 4704 kW/hall | 42.3 MW/cluster
Common : 8 modules | 300 kW/module | 600 kW/hall | 2.4 MW/cluster



Overall Indicators

Total land area	14850 m2
DC Building area	9470 m2 (Excluding the area of steel platform and cooling station)
Total IT power	44.7 MW
IT liquid cooling rack	132 kW/rack, 8 racks/module, 288 in total
Network rack	12 kW/rack, 10 racks/module, 360 racks in total
Common rack	10 kW/rack, 30 racks/module, 240 racks in total
Design grade	Tier III
IT/Cooling power backup	10 min
Reference PUE	1.13

Block diagram

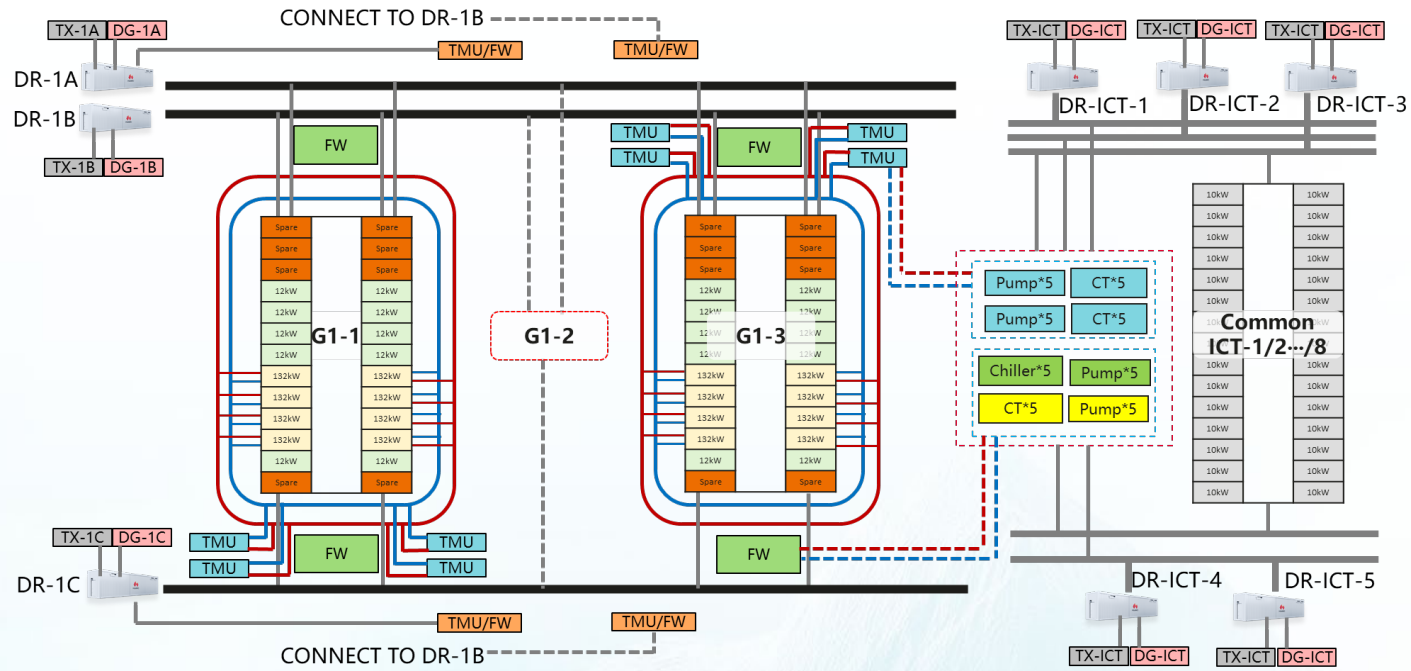

Remarks:

1. One set of 3DR power distribution architecture is configured for every 3 modules, total 12 sets
2. Common ICT and mechanical devices share a 5DR power distribution architecture.

	Outdoor PowerPOD		Fan Wall		Thermal Management Unit
	Diesel Generator		Liquid supply		Liquid Return

Power system

Cooling system

Architecture*	IT: 3DR*12 Common+ME: 3DR	Air-to-liquid ratio	2:8 (1:9-3:7) Common: 100% air
Power module	IT: 3.0MW*36 Common+ME: 1.8MW*5	Fan wall/hall	IT: 210 kW*(12+2) Common: 210 kW*(4+1)
Transformer	2500 kVA*41	TMU/hall	360 kW/set, (3+1) *6
Diesel generator	2400 kW DCC*41	Cooling tower	505 m ³ /h, (4+1)*2
Busbar	630A	Chiller	4220 kW, 4+1

* Note: Power distribution architecture supports 2N, DR, and BR.

Design Overview

IT Load: 50 MW@21 kW/rack

Liquid Cooling: 48 modules | 840 kW/module | 5040 kW/hall | 40 MW/cluster

Air Cooling: 18 modules | 552 kW/module | 4968 kW/hall | 10 MW/cluster



Overall Indicators

Total land area	40800 m2
DC Building area	23000 m2 (Excluding the area of steel platform and cooling station)
Total IT power	50 MW
liquid cooling rack	21 kW/rack, 40 racks/module, 1920 in total
Air cooled rack	12 kW/rack, 46 racks/module, 828 racks in total
Design grade	Tier III
IT/Cooling power backup	10 min
Reference PUE	1.13

FusionPower9000

Product Brief

The Huawei PowerPod FusionPower9000 provides a decoupled and flexible power supply and distribution system solution for medium and large data centers. This solution integrates power supply and distribution units, UPSs, lithium batteries, air conditioners, and fire extinguishing systems into a ultra-high protection 40-foot container. One single container supports a maximum power capacity of 2.4 MVA. It can be quickly deployed outdoors and expanded on demand.

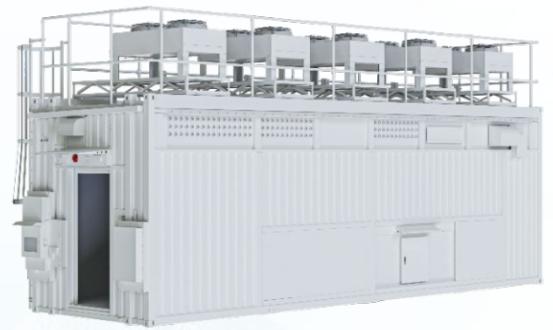

Product Appearance

Application Scenario

- Outdoor integrated power supply and distribution system for medium and large data centers

Features and Benefits

Secure and reliable

- Isolated architecture, away from Data Hall
- Factory pre-integration, reduce installation on-site, ensure high quality

Rapid deployment

- Engineering productization and concurrent construction on-site+Factory
- Product modularization, high assembly efficiency in factory assembly line

Elastic capacity expansion

- One power supply in one container, on-demand capacity expansion
- Building decoupling, flexible and match different IT capacity

Intelligent O&M

- Full-link visualization and intelligent O&M
- Temperature prediction of copper bar nodes
- breaker health evaluation

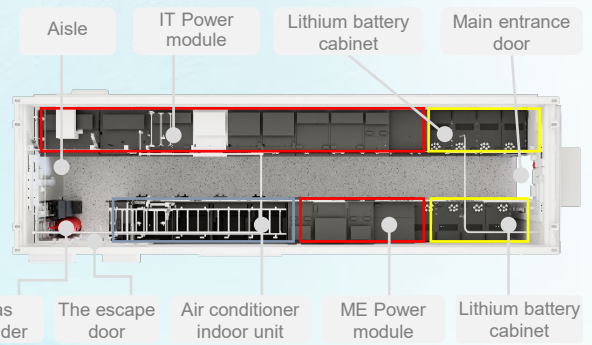

Internal layout (for reference only)

FusionPower9000

Technical specifications

Configuration		Configuration 1 IT-only (2.4MVA)	Configuration 2 IT+ME (2.4MVA)	Configuration 3 IT+ME (2.4MVA)	Configuration 4 IT+ME+Grid Output Cabinet (2.4MVA)
	Deployment Site	Outdoor			
	Altitude Range	≤ 4000 m (derating over 1000 m) ^①			
	Number of stack layers	Stacking is not supported (based on the load performance described in the following table)			
	Operating humidity	5% ~ 95%			
	Operating ambient temperature	-20°C ~ +55°C			
	Storage Humidity	5% ~ 95%			
	Storage temperature	- 40°C ~ +70°C			
	Environmental adaptability	Class A/B environment ^②			
	Maintenance channel Illuminance	300Lux			
	Lifecycle of the entire system	10 years ^③			
	Container life	25 years			
Structure Parameters	Carrying capacity	12KN/m ²			
	Seismic performance of the container	Meets NEBS GR63-ZONE3 seismic requirements			
	Snow load capacity	0.718KN/m ²			
	Wind resistance	Meets the requirements of level-12 typhoons			
	Transportation weight of the entire system	35t	38t	37.2t	33.5t
	Operating weight of the entire system	46t	48.5t	47.7t	41.5t
	Length x width x height	12192mm×3495mm×4150mm			
	Protection level of the entire system	IP55			
	Flooring	No raised floor, installed on the floor			
	Input power supply	Three-phase, four-wire + PE, 380V AC/400V AC/415V AC 50/60Hz ^④			
Electrical Parameters	Main input	Grid: 4000 A/4P D.G.: 4000 A/4P CB-level ATS	Grid: 4000 A/4P D.G.: 4000 A/4P CB-level ATS	Grid: 4000 A/4P D.G.: 4000 A/4P CB-level ATS	Grid: 4000 A/4P D.G.: 4000 A/4P CB-level ATS
	Grid Feeder	/	/	/	ACB 1*1000A/4P MCCB 3*250A/4P + 1*160A/4P
	ME UPS	/	1×600kVA@MAX	1×600kVA@MAX	1×600kVA@MAX
	ME UPS Main Input	/	1250A/3P+N	1250A/3P+N	1250A/3P+N
	ME UPS Test	/	/	/	1000A/4P
	ME Maintenance Bypass + Main Output	/	2*1000A/4P	2*1000A/4P	2*1000A/4P
	ME UPS Feeder	/	MCCB 6*250A+1*160A	MCCB 6*250A+1*160A	MCCB 6*250A+1*160A
	IT UPS	4×600kVA@MAX	3×600kVA@MAX	3×600kVA@MAX	2×600kVA@MAX
	IT UPS Main input + Maintenance bypass	(4000A/3P+N)+ 4000A/4P	(3200A/3P+N)+ 3200A/4P	(3200A/3P+N)+ 3200A/4P	(2500A/3P+N)+ 2000A/4P
	IT UPS test	4000A/4P	3200A/4P	3200A/4P	2000A/4P
	IT UPS main output cabinet	4000A/4P	3200A/4P	3200A/4P	2000A/4P
	IT UPS bus output cabinet	3200A/4P	2500A/4P	3200A/4P	2000A/4P
	IT UPS cable output	MCCB 6*250A+1*160A	MCCB 6*250A+1*160A	/	/

FusionPower9000

Technical specifications

Configuration		Configuration 1 IT-only (2.4MVA)	Configuration 2-1 IT+ME (1.8MVA+0.6MVA)	Configuration 2-2 IT+ME (1.8MVA+0.6MVA)	Configuration 3 IT+ME+Mains Output (1.2MW+0.6MVA+0.6MVA)
Electrical Parameters	Operating temperature	Cold aisle: 20°C ~ 30°C at Full Load			
	Battery parameter	SmartLi 3.0			
	Number of battery cabinets	8	8	7 ~ 8 ⑤	5 ~ 6 ⑤
	Power backup time	10min@SOL			
Temperature control Parameters	Cooling Capacity of each Air conditioner	55kw ^⑥			
	Quantity	N+1 or N ^⑦			
	Refrigerant	R410A			
	Air intake channel for UPS and lithium battery cabinet Temperature Range	20°C ~ 30°C at Full Load			
	Air intake channel of the equipment Humidity Range	5% RH ~ 80% RH			
Fire fighting Parameters	External enclosure structure Refractory time	Four walls for 120 minutes; Top for 120 minutes; Bottom for 30 minutes			
	Fire doors Refractory time	90min			
	Fire sprinkle system	Fire sprinkler system pipe network is optional in factory			
	Gas fire extinguishing system	Gas-extinguishing system pipe network is prefab in factory by default; Gas cylinders and accessories need to be provided locally.			
	Gas fire extinguishing Alarm system	Need to be provided locally.			
Monitoring Parameters	Environment and Supervision system	Centralized collection and management of the standard ECC			
	Room-level access control System-Security	Standard access control; The main entrance door is equipped with access control, and the IC card reader is used. Door status sensor for the emergency door			
	In-room CCTV system - security	Standard CCTV system; 2 MP semi-dome camera, 7 days storage by default (SD card, 512 KB code stream) ⑧			
	Temperature and Humidity Detection	Standard configuration: 2 PCS for cold aisle temperature and humidity monitoring			
	Water sensor system	Water leakage detection of dehumidifier and air conditioner, non-locating rope type			
Intelligence Features	Power supply and distribution link Panorama	(Optional) Panoramic display of power supply and distribution links from the mains/diesel generator cable inlet cabinet to the feeder cabinet			

Note:

- ① When the altitude exceeds 1000 m, the power supply and distribution are derated according to EN/IEC 62040-3. Obtain the cooling power based on the Huawei temperature control component derating parameter table, the overall derating coefficient is the one with the largest derating coefficient.
- ② The container meets the requirements of Class C environment.
- ③ The lifecycle refers to the designed life of the power module when it meets the power output and heat dissipation requirements under the designed load. The PAD/APF component could not service 10 years..
- ④ By default, the nominal capacity and breaker selection are calculated based on the 400 V voltage level. If the voltage of a specific project is low, check whether the current exceeds the specified specification after calculation. Otherwise, derate the nominal capacity.
- ⑤ When the UPS load is less than 300 kW, only the master cabinet can be configured with 10-minute backup power.
- ⑥ A080 outdoor unit is used under T1 working condition; A110 outdoor unit is used under T3 working condition.55kw rated condition is Indoor return air 35°C, outdoor air 35°C;
- ⑦ For configuration 1 or 2 on the T1 working condition, and at the ambient temperature of 45°C, five air conditioners are configured in N+1 mode.For configuration 3 on the T3 working condition, and at the ambient temperature of 55°C, four air conditioners are configured in N+1 mode.
- ⑧ The fire extinguishing system needs to be provided and installed locally because the fire extinguishing system needs to be accepted locally. Gas fire extinguishing system accessories include: pressure breaker, solenoid valve, high pressure hose, nozzle, etc. The components of the fire alarm system include the fire extinguishing host, alarm bell, audible and visual alarm, gas release indicator, smoke sensor, temperature sensor, stop button, manual alarm, status display box, addressing CM module, and I/O module.
- ⑨ If the customer requires storage for more than seven days, connect the breaker to the building video storage system for storage capacity expansion.

UPS5000-H

(300~1600 kVA) 3P4W

INTRODUCTION

UPS5000-H is Huawei's medium and large-scale uninterruptible power supply system with advanced 100kVA/3U hot swappable power modules. The system achieves 1 MW,1 rack, effectively saves footprint and installation time. System efficiency is up to 97%. Intelligent iPower improves system reliability and simplifies operation and maintenance for customers. The S-ECO(Super ECO) mode achieves not only 99.1% efficiency and optimal power quality but also 0ms mode transferring.



Power Module: 100kVA/3U

APPLICATION SCENARIOS

- Data centers in headquarter or disaster recovery data centers
- Internet data centers
- Large cloud computing data centers

FEATURES & VALUE

Simple

- Hot swappable power module, bypass module and control module simplify maintenance and expansion in 5 minutes
- Top bus way prefabricated design, reducing on-site installation time by 60%
- Support global voltage formats

Green

- 1 MW, 1 rack, saving the footprint by 50%
- Online mode: 97% system efficiency, high efficiency at light-load
- S-ECO mode: 99.1% system efficiency, saving 140,000\$ in lifetime
- S-ECO mode active filtering, optimal power quality

Smart

- iPower pre-warnings for key components by AI method
- Source share of main and battery achieves intelligent peak shaving, eliminating the reconstruction of grid.

Reliable

- Redundant architecture eliminates single point of failure
- S-ECO mode: non-interruptible mode transferring.



UPS5000-H-400/500/600kVA



UPS5000-H-800kVA



UPS5000-H-1200kVA



UPS5000-H-1600kVA

UPS5000-H

(300~1600 kVA) 3P4W

Model		UPS5000-H-400/500/600k	UPS5000-H-800k	UPS5000-H-1200k	UPS5000-H-1600k
Capacity	Rack capacity	400/500/600kVA	800kVA	1200kVA	1600kVA
	Module number	2-4/2-5/2-6	2-8	2-12	2-16
Mains input	Input wiring	3PH+N+PE			
	Rated voltage	380/400/415Vac			
	Voltage range	138-485Vac (100% load: 323-485V)			
	Frequency range	40-70Hz			
	Total harmonic distortion	Normal mode: THDi<3% for 100% linear load S-ECO mode: THDi<3% for 100% linear load			
	Input power factor	Normal mode: 0.99; S-ECO mode: 0.99			
Bypass input	Input wiring	3PH+N+PE			
	Rated voltage	380/400/415Vac			
	Input frequency	50/60±6Hz			
Battery	Rated voltage	360-600Vdc (the number of VRLA can be selected from 30 to 50; 40 batteries rated, no battery neutral, support odd battery number); 512Vdc(huawei SmartLi)			
	Maximum charge capacity and current	Single power module: 15%, 30A			
	Battery category	Huawei SmartLi, VRLA			
	Battery sharing	Support (VRLA)			
Output	Output wiring	3PH+N+PE			
	Voltage	380/400/415Vac±1%			
	Frequency	Tracking the bypass input (normal mode); 50/60hz±0.05% (battery mode)			
	THDv	THDv<1% for linear load			
	Overload capacity	Inverter: 100% < load≤110% for 60 minutes, then transfer to bypass mode; 110% < load≤125% for 10 minutes, then transfer to bypass mode; 125% < load≤150% for 1 minute, then transfer to bypass mode			
System	Output power factor	1			
	Efficiency	Normal mode: up to 97% S-ECO mode: up to 99%			
	Source share mode	Support main input and battery joint operating			
	Parallel	6	4	4	2

UPS5000-H

(300~1600 kVA) 3P4W

Model		UPS5000-H-400/500/600k	UPS5000-H-800k	UPS5000-H-1200k	UPS5000-H-1600k
Capacity	Rack capacity	400/500/600kVA	800kVA	1200kVA	1600kVA
	Module number	2-4/2-5/2-6	2-8	2-12	2-16
Mains input	Input wiring	3PH+N+PE			
	Rated voltage	380/400/415Vac			
	Voltage range	138-485Vac (100% load: 323-485V)			
Environment	Operating temperature	0-40°C			
	Storage temperature	-40-70°C			
	Relative humidity	0%-95% (no condensing)			
	Operating altitude	0-2000m. Above 2000m, derating based on EN/IEC 62040-3			
Others	Weight	580kg/690kg/800kg	1300kg	1600kg	2300kg
	H*W*D(mm)	2000*800*1000	2000*1600*1000	2200*1600*1000	2200*2400*1000
	Standards and certifications	Standards: EN/IEC 62040-1, EN/IEC 62040-2, EN/IEC 62040-3 Certifications: CE; CB; rohs, REACH, WEEE, etc.			
	Communications ports and protocol	Communications ports: dry contacts, RS485, FE Communications protocol: web, Modbus and SNMP			
	Mobile surveillance	Supports intelligent mobility management			

Note: Tier4 or Tier3 levels specified in T1942 are required, that two UPSs form a dual bus or a UPS and utility form dual bus for important systems related to major economy or public safety, such as civil aviation management centers, financial liquidation centers and trading centers, etc.

SmartLi 3.0

INTRODUCTION

SmartLi is a battery energy storage system developed by Huawei for UPS, which has the features of safety and reliability, long lifespan, space saving and easy maintenance. LFP is the safest cell of Li-ion battery. The unique active current balance control technology supports the mix use of new and old batteries, which reduces Capex (Capital Expenditure). Three-level BMS system realizes intelligent battery management with Huawei UPS and Network management system, which reduces Opex (Operating Expense).

APPLICATION SCENARIOS

- Data centers in headquarter or disaster recovery data centers
- Internet data centers
- Large cloud computing data centers

FEATURES & VALUE

Reliable

- Long cycle lifespan, cycle lifetime can be up to 5000 times
- Highly stable LFP cell, no fire after thermal runaway
- Three-level BMS system ensures reliability
- Battery Module-level fire extinguishing, precise and quick fire fighting

Efficient

- High power density, saving 70% footprint
- Smart BMS system, saving 80% routine O&M costs

Simple

- Active current balance control, supporting new and old battery cabinets mixed using, flexible to expand
- Smart active voltage balance control, Battery strings of different numbers of lithium batteries can be connected in parallel ④
- Automatic grouping and capacity check, reducing manual capacity test costs and avoiding power failure risks



SmartLi 3.0 ST

SmartLi 3.0

SPECIFICATIONS

	Item	Description
Basic Parameters	Product Model	SmartLi
	Battery Cell Material	LiFePO4(6C)
	Charging Current	≤ 1C, 0.5C by default
	Maximum discharge current (battery module)	459A
	Maximum discharge current (battery cabinet)	630A (6+6) (7+7) (8+8) , 315A (6+0) (7+0) (8+0)
	Cycle Life	5000 cycles @ 50% DOD
	Nominal Capacity	162Ah / 82.94kWh (8+8) ; 162Ah / 72.57kWh (7+7) ; 162Ah / 62.20kWh (6+6) ;
	Capacity for calculating the backup time ^②	153Ah / 78.33kWh (8+8) ; 153Ah / 68.54kWh (7+7) ; 153Ah / 58.75kWh (6+6) ;
	Weight	1100kg (8+8) ; 1000kg (7+7) ; 900kg (6+6)
	Dimension (W*D*H)	600mm*850mm*2000mm
	Self Discharge	≤5% (0-30°C/3 months)
	Communication Interface	FE, RS485, Dry contacts
	Protection	Over temperature, over current, short circuit, over charge/discharge, etc.
	Certification	UL1642, UL1973, UN38.3, UL9540A, IEC62619, IEC62133, IEC62477, IEC62040
	Compatibility	Huawei UPS
Discharge capability	300 kW@10 minutes or 200 kW@15 minutes (7+7, 20-30° C)	
Environment	Storage Temperature	0°C - 60°C
	Transportation Temperature	-40°C to 60°C
	Operating Temperature	0°C - 40°C (20-25° C is recommended)
	Relative Humidity	5% - 95%
	Max. Operating Altitude	0 - 4000m. Derating is required if the altitude exceeds 1000 m*

② The backup time is calculated based on the capacity 68.54 kWh and the capacity under different backup time or discharge rates.

68.54kWh=25.5Ah*3*2*3.2V*20*7 (The battery cell is 27 Ah. The margin is calculated based on the reserved 25.5 Ah. For details, refer to the battery cell certification report.)

FusionCol600-L450MA

Thermal Management Unit (TMU)

INTRODUCTION

FusionCol600-L450MA is launched for high-density large-scale AI DC, it is green, reliable, simple, and intelligent, which help customer building a high-quality liquid cooling solution.

By adjusting secondary-side coolant temperature and flow volume, TMU exchanges the heat from IT equipments to primary-side through the built-in heat exchanger. It ensures the IT equipments running stably at a proper temperature, facilitating the efficient and energy-saving operation.

APPLICATION SCENARIOS

- High-density large-scale AI DC
- Carrier IDC
- e-Government Cloud DC, and DC for provincial/municipal government

FEATURES

Green

- Efficient centrifugal pump, automatically adjusting frequency based on system pressure and flow volume.
- High-temperature liquid supply and return, reducing system power consumption.
- Pressure difference control, dual backup sensors, preventing single-point failures.
- Intelligent teamwork control, rotating operation, dynamic allocation of cooling capacity, and unified regulation of pumps, enhancing energy efficiency.

Reliable

- Dual power supply switching with "zero interruption", no fluctuation in liquid supply, and no server temperature rise.
- THDi < 10% (full load) , power factor $\geq 95\%$ (full load) , enhancing power supply stability.
- One-click emergency stop, ensuring personal and device safety.
- One-click maximum cooling, 20s quick startup, 5 minutes emergency liquid replenishment, direct mains-powered pump operation.
- One-click automatic inspection of the expansion tank and online maintenance of key components, ensuring uninterrupted cooling.
- Core components are designed with 2N, such as power distribution modules and pumps. Single-point failures do not affect liquid cooling system operation.

Simplified

- Elevating castors; key components maintained from front or back, without removing the unit from the row.
- Separated design of motor and drive, enhancing pump maintainability.
- Main control module, auxiliary power module, power module, and drive module supporting hot-swappable maintenance within minutes.

Intelligent

- Startup wizard, automatically collecting running data and evaluating key components status, simplifying O&M.
- Pump operates on demand, with the backup intelligently rotating to prevent liquid stagnation and pipe blockage.
- Self-suction liquid replenishment, liquid storage tank equipped replenishment pump, enabling tool-free self-suction liquid replenishment.



FusionCol600-L450MA

FusionCol600-L450MA

Thermal Management Unit (TMU)

Technical Specifications

Specifications	Unit	FusionCol600-L450MA
Cooling capacity	kW	450(dual-pump)/ 360(single-pump)
Power supply	V/Ph/Hz	380-415/ 3 / 50/60
Number of water pumps	PCS	2 (Pumps started and stopped synchronously / one runs as active pump, another standby)
Water flow on the secondary side	m ³ /h	39/31.2
Available lift on the secondary side	kPa	250/180
Primary side inlet and outlet liquid rated temperature	°C	37/45
Secondary side supply and return liquid rated temperature	°C	40/50
Primary side inlet and outlet liquid pipeline interface	in	3, Quick-connect chuck interface (Chuck outer diameter: 91 mm; Welded pipe outer diameter : 76 mm)
Secondary side supply and return liquid pipeline interface	in	3, Quick-connect chuck interface (Chuck outer diameter: 91 mm; Welded pipe outer diameter : 76 mm)
Precision of the filter on the primary side	mesh	50
Precision of the filter on the secondary side	mesh	270
Pipe routing mode	-	Bottom piping
W x D x H	mm	600 x 1,200 x 2,250
Net weight	kg	700
Communication interface	-	RS485、FE and USB with security protection mechanism
Communication protocol	-	Modbus-RTU、Modbus-TCP、SNMP

Remarks:

1. Rated working conditions: primary side inlet and outlet liquid 37°C / 45°C, water; Secondary side supply and return liquid 40°C / 50°C, deionized water.
2. Operating temperature range: primary side inlet temperature range: 10°C ~ 50°C; Secondary side supply temperature range: 20°C ~ 60°C.
3. The equipment supports dual-pump and single-pump operating modes. The cooling capacity, water flow and available lift are technical parameters of rated working conditions when the equipment works in dual-pump or single-pump mode.
4. The above parameters are only reference values during the product development phase and may significantly differ from the actual parameters of the final product. Therefore, the information contained in this document is for reference only and does not represent any form of commitment or guarantee.

FusionCol8000-C210H

In-room Chilled Water Smart Cooling (Fan Wall)

INTRODUCTION

FusionCol8000-C smart cooling product is part of the chilled water cooling system working with chillers, water pumps and etc. Horizontal air flow, efficient fans and heat exchanger helps to bring better, more efficient cooling to data centers.

APPLICATION SCENARIOS

- Medium and large modular data center
- Medium and large equipment room
- Large cloud data center

FEATURES & VALUE

Green

- High in/out chilled water temperature up to 20 °C, reducing cooling power consumption.
- Efficient EC fans save up to 30% energy compared with traditional AC fans.

Reliable

- Dual power supply with automatic switch. “0” cooling interruption during power switch.
- 6kV surge protection.

Simple

- Horizontal air flow. No need for raised floor.
- The controller, DC power, and fan driver adopt modular hot-swappable design and support minute-level maintenance without cooling interruption risk.

Smart

- Fault self-diagnosis and intelligently eliminate root causes of irrelevant faults, saving O&M time.
- Real-time display of electrical power, supporting integration of AI energy efficiency optimization system1.



FusionCol8000-C210H
(Return air side)



FusionCol8000-C210H
(Supply air side)



FusionCol8000-C internal components

SPECIFICATIONS

	Unit	FusionCol8000-C210H
Air Flow	-	Horizontal
Total Cooling Capacity	kW	210
Air Flow Rate	m ³ /h	53,000
Power Supply	V/Ph/Hz	380V AC ~ 415V AC, 3Ph+PE, 50Hz/60Hz
Quantity of Fans	PCS	4
Air Filter Class	-	G4
Dimension: H×W×D	mm	2350×1100×2450
Net Weight	kg	1000

Remark:

- Nominal condition: return air temperature 36°C, 24%RH, inlet/outlet water temperature 20 °C/28 °C.

Huawei Technologies Co., Ltd.
Huawei Base, Bantian, Longgang District, Shenzhen
Telephone: + 86 755 28780808
Postcode: 518129 www.huawei.com

Trademark Statement

 Huawei is a trademark or registered trademark of Huawei Technologies Co., Ltd. Other trademarks, product names, service names, and company names used in this document and in the products described in this document are owned by their respective owners.

Disclaimer

This document may contain forecast information, including, but not limited to, information about future financials, operations, product lines, new technologies, etc. Due to the many uncertainties in practice, the actual results may be greatly different from the forecast information. Therefore, the information in this document is for reference only and does not constitute any offer or commitment. Huawei is not liable for any actions you make based on this document. Huawei may modify the above information without prior notice.

Copyright © Huawei Technologies Co., Ltd. 2024. All Rights Reserved.

Without the written consent of Huawei Technologies Co., Ltd., no unit or individual shall excerpt or copy part or all of the contents of this manual, and shall not disseminate it in any form.